

The Origins and Present Status of the Radio Wave Controversy in NMR

D.I. HOULT

Institute for Biodiagnostics, National Research Council, Winnipeg, Canada

ABSTRACT: The origins, history, and present status of the controversy surrounding a quantum description of the NMR signal as being due to radio waves are traced. With the Principle of Relativity and Coulomb's Law as formal starting points and the minimum of mathematics needed for understanding, the derivation of a classical electromagnetic theory of signal reception is first given. The agreement between that classical theory and a recent NMR experiment is then presented, leading to proof that, except for the highest field imaging experiments, there is no significant contribution of radio waves to the signal. Attention is drawn to the very different properties of the near and far energy, momenta, and fields inherent in the derivation. The role of the Correspondence Principle in formulating a quantum description is then emphasized and it is shown that the standard NMR *interpretation* of Dicke's theory of coherent spontaneous emission—that the latter is responsible for the NMR signal—cannot be correct. Finally, the author speculates on some of the intriguing relationships found in the classical electrodynamics of NMR signal reception and attempts to relate them to a common quantum electrodynamic precept of near field interaction: that the free induction decay voltage present at the terminals of an open-circuit receiving coil is based on an exchange of virtual photons between the nuclei in a sample and the free electrons in a receiving coil. © 2009 Crown in the right of Canada. Concepts Magn Reson Part A 34A: 193–216, 2009.

KEY WORDS: radio waves; coherent spontaneous emission; Faraday induction; virtual photons; Uncertainty Principle

The resolution of the paradoxes of atomic physics can be accomplished only by further renunciation of old and cherished ideas. —W. Heisenberg. 1930. *The Physical Principles of the Quantum Theory*.

Received 6 April 2009; revised 12 May 2009; accepted 21 May 2009

Correspondence to: D.I. Hault; E-mail: david.hault@nrc-cnrc.gc.ca

Concepts in Magnetic Resonance Part A, Vol. 34A(4) 193–216 (2009)

Published online in Wiley InterScience (www.interscience.wiley.com). DOI 10.1002/cmra.20142

© 2009 Crown in the right of Canada.

INTRODUCTION

Following the application of a 90° pulse to a sample of water, an easily measured alternating voltage at the Larmor frequency is generated across the terminals of a coil surrounding the sample. How is this electromotive force created by the precessing protons?

Twenty years ago in this journal (*I*), the author attempted to correct what appeared to be a simple conceptual error in descriptions of nuclear magnetic

resonance (NMR) spectroscopy and imaging (MRI): to wit the belief that the NMR free induction decay (FID) signal from an excited sample is due to the emission of radio waves. He little knew, however, that this was to lead him into conflict with NMR luminaries of a previous generation and also into difficult and disputed areas of modern physics. In 1989, MRI field strengths were generally in the range 0.5–1.5 T with the corresponding proton Larmor frequencies being 21 to 64 MHz. As the wavelength λ of radio waves in this bandwidth (14.3–4.7 m) is much greater than the usual size (<0.5 m) of the excited volume in a human, it was transparently self-evident to any electrical engineer that MRI (at least in those days) was “near-field.” In other words, the emission of radio waves was a negligible phenomenon and, following a pulse, the MR signal created in a receiving coil was due to Faraday induction, as in “free induction decay.” Similar conclusions also applied to spectroscopy with its higher fields but smaller sample sizes.

Surprisingly, however, instead of diminishing with the publication of the attempted correction and a further clarification (2), the myth of radio waves only seemed to intensify. A medical colleague provided enlightenment by explaining that academic radiologists were talking to physicists in their universities who were assuring them that it had been shown many years before that the MR signal was due to “coherence-brightened spontaneous emission” of photons. Such emission was interpreted as the production of radio waves at the frequencies of interest. A literature search soon revealed that the fathers of this idea were Purcell (3), Dicke (4), and Bloembergen and Pound (5); formidable parents indeed, carrying the weight of physics Nobel prizes and apparently unimpeachable authority. Yet unless others’ and my understanding of Maxwell’s equations was somehow hopelessly wrong, there had to be a flaw, for a theory of radio wave emission leads to incorrect dependences of signal strength on frequency and filling factor, as will be seen later. Notwithstanding, I also realized that ultimately an experiment would be needed to clarify matters. That rather difficult experiment was finally performed in 2000 (6) and it fully confirmed the accuracy of classical electromagnetic calculations of NMR signal strength, the negligible role of radio waves and by extension, the misapplication of Dicke’s theory of coherent spontaneous emission (4).

In hindsight, the growth of the myth of radio waves was a result of several factors: the passage of NMR from physics into chemistry in the 1950s with a lessening of involvement of cutting-edge physicists; the consequent ignorance in the field of the development of the quantum physics of electromagnetic

interactions (quantum electrodynamics, QED); the lack among physicists of a detailed understanding of the electronics of low-noise, radio-frequency (RF) signal amplification and, most importantly, the failure to verify against experiment a theory that was “obviously” correct. There remains, however, the nagging issue of a true quantum explanation of the NMR free induction decay, for it is important to have an integrated, accurate, and complete body of quantum NMR theory that applies to all aspects of the phenomenon. Generalizing the issue, what is the correct quantum description of Faraday induction? The author knows of no article on this topic and only one that comes close (7), but for any ambitious theoretical physicist attempting an answer, spin-1/2 NMR probably provides the simplest of all models from which to start.

Let us then look more closely at the various factors involved in the controversy. To begin, we invoke the approach, well known in the philosophy of physics, of drawing a clear demarcation between the phenomenon and the observer of that phenomenon. It is vital that the reader understand that “signal reception” for the purposes of the present discussion comprises two distinct and separate operations:

1. The generation of a voltage in an *open-circuit* receiving coil placed around the sample (the phenomenon);
2. The connection of that coil to an electronic amplifier, the receiver, in a manner that minimises the addition of extra noise (so-called “noise matching”) so as to allow optimal observation of the voltage (the act of observation, or colloquially “the observer”).

The latter interactive operation, whose design lies squarely in the realm of RF electronic engineering, is a possibly severe perturbation on the phenomenon that can distort its analysis. It is also an arbitrary perturbation: the reader is reminded that noise matching can be accomplished with diverse circuit designs that influence dramatically the current that flows in the coil during signal reception (and hence the degree of coupling of observer and phenomenon via the resulting B_1 field, “radiation” damping), *all the while maintaining optimal signal-to-noise ratio*. (This poorly understood but conceptually important topic in electronics engineering is further explored in Appendix A.2.) Thus, in contrast to early articles that included in their analyses a special and primitive case of noise matching (a tuned, high Q-factor LC circuit) that strongly coupled to the NMR system and essentially created a new entity, our goal will be to

investigate Operation 1 in a manner that removes the observer's perturbing role. Without an appreciation of this basic philosophy, the reader may be truly perplexed by what follows. (The coil by itself is a negligible perturbation.) As there must, of necessity, be observation to obtain information upon which to draw conclusions, there may be those who question whether, in a quantum context, making such a cut between phenomenon and observer is a valid philosophy. However, arguments are presented to show that for NMR signal reception it is, because it is the limit of a well-behaved analytical electronic process.

Of primary initial importance, for it is in agreement with experiment (6), is an accurate classical electromagnetic description of NMR signal reception using the concepts and terminology of electricity and magnetism that are broadly accepted in both the physics and electrical engineering communities. Thus we begin with this topic, while attempting to restrict a proliferation of mathematics that could obscure the underlying physics, and trying throughout to give insights into the rich texture of electromagnetism. (The reader may be able to skip the equations while retaining the gist of the arguments.) Then we move on to one of the early foundations of quantum mechanics and remind the reader of the judicious use of Bohr's Correspondence Principle in striving to derive a correct quantum mechanical description of any phenomenon that is accurately describable classically. Next, the circumstances that gave rise to the erroneous assumption that coherent spontaneous emission was responsible for the NMR signal are described as best the author can 50 years later, and finally, some unsatisfactory and incomplete pointers to an unsettling (and unsettled) QED explanation—virtual photon exchange—are given. It is, of course, impossible in one short article to cover in detail the full sweep of the topic. However, to illustrate his points and to provide the best that physics can offer for those who lack familiarity with the subject matter, the author has deliberately selected as references mainly undergraduate texts by eminent scientists such as Born, Feynman, Jackson, Ohanian, Purcell, and Taylor and Wheeler (8–13, respectively).

CLASSICAL DESCRIPTION OF NMR SIGNAL RECEPTION

The Electric Field of a Rotating Magnetic Moment

Nuclear magnetic resonance of a simple spin-1/2 species, such as hydrogen in water, is a classical phe-

nomenon as has been recently emphasized in this journal by Hanson (14). This deceptively simple statement implies that excitation of the protons in, for example, 1 ml of H₂O at 100 MHz, and the subsequent reception of a signal via the voltage created in a surrounding coil, can be described by a nonquantum theory of physics *in accord with experiment*. (Note that the distinction between a *theory* and a *hypothesis* in physics rests firmly on experimental validation.) The fundamental starting points of a classical description are perhaps in the eye of the beholder, but for the purposes of this article, they are Einstein's Principle of Special Relativity (13) and Coulomb's Law of electrostatic force *in vacuo* (10–12)

$$\mathbf{E} = \frac{q}{4\pi\epsilon_0 r^3} \mathbf{r} \quad [1]$$

Using SI units here and throughout the article, \mathbf{E} is the electric field at a point of interest, q is a point charge, the source of the field, ϵ_0 is the permittivity of free space, and \mathbf{r} is the vectorial distance from the charge to the point of interest. From these origins, Maxwell's equations of electromagnetism can be derived and with them, the full panoply of relationships that are the domain of classical electromagnetism. (Note that Jackson (10, p 578) finds fault with many derivations and has pithy comments thereon.) The author's favorite derivation is that of Ohanian (11, Ch. 8); it utilizes the concept of vector potential \mathbf{A} and is also reasonably accessible. Here, we assume that derivation and continue by asserting that in the absence of charge *inside* the volume of interest, both magnetic \mathbf{B} and *electrodynamic* (nonstatic) \mathbf{E} fields can be derived from the well-known equations:

$$\mathbf{B} = \text{curl}\mathbf{A}; \text{curl}\mathbf{E} = -\frac{d\mathbf{B}}{dt} \quad [2]$$

Now consider a circuit carrying an alternating flow of charge—current of amplitude I_0 . At a point in space P shown in Fig. 1, vector potential \mathbf{A} is related to current I_0 in both direction and size by the equation (10, section 6.6)

$$d\mathbf{A} = \mu_0 I_0 \frac{d\mathbf{S}}{4\pi R} \exp(i\omega[t - R/c]) \quad [3]$$

Here ω is the current's angular frequency, $d\mathbf{s}$ is a vector element of the circuit at a point Q, R is the distance between points Q and P, $\mu_0 = 4\pi \cdot 10^{-7}$ H/m is the permeability of free space, and c is the speed of light *in vacuo*. Note that in general, current I_0 may well be a function of position Q in both amplitude and phase (see problem 2, Appendix B.1.). If Eq. [3]

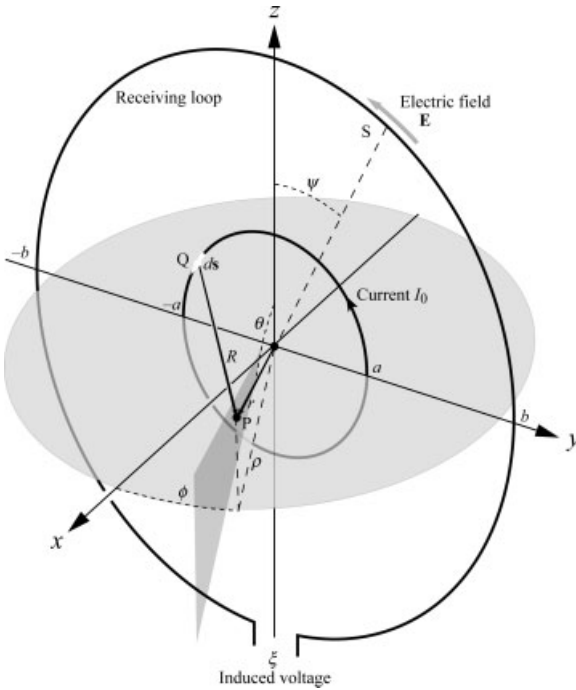

Figure 1 A loop of radius a in the yz plane carrying alternating current of amplitude I_0 induces a voltage ξ in a coplanar receiving loop. To determine that voltage, the vector potential and thence the electric field from a current element of length ds at Q are first calculated at an arbitrary point P a distance R away from Q . Point P is at spherical polar coordinates $[r, \theta, \phi]$. (In cylindrical polar coordinates, point P is at $[\rho, \phi, z]$). The electric field from all such elements is then integrated round the receiving loop to yield ξ .

is unfamiliar, it is perhaps because of the inclusion of the exponential term. It describes what is sometimes called a “retarded potential” and explicitly incorporates the delay (due to the finite speed of light) in the propagation of a *changing* potential through space from Q to P . Note that the expression does not include any relativistic change in ds and R and hence $d\mathbf{A}$ due to the motion of the electrons comprising the current (c.f. Jackson, 10, Ch. 17). The full potential \mathbf{A} is obtained by integrating round the circuit and as $d\mathbf{A}$ is parallel to ds , we note that for the circular loop of Fig. 1, \mathbf{A} must be tangential to the loop.

We started with Coulomb’s Law of electrostatic force, but to find the electrodynamic alternating electric field associated with the changing current in the circuit, we use Maxwell’s form of Faraday’s equation; *viz* from Eq. [2]

$$\text{curl}\mathbf{E} = -\frac{d\mathbf{B}}{dt} = -\text{curl}\frac{d\mathbf{A}}{dt} \quad [4]$$

It follows from this differential equation that we may equate \mathbf{E} directly with $d\mathbf{A}/dt$ (i.e., $-i\omega\mathbf{A}$) with the understanding that we lack a constant of integration, in other words, conservative electric fields that begin and end on charges. Thus, from Eq. [3], the dynamic electric field associated with an alternating current element ds is

$$d\mathbf{E} = -\frac{d\mathbf{A}}{dt} = -i\omega\mu_0 I_0 \frac{ds}{4\pi R} \exp(i\omega[t - R/c]) \quad [5]$$

and $d\mathbf{E}$ is parallel to ds .

Evaluation of the integral of Eq. [5] to obtain the full electric field from an entire circuit is, in general, best performed numerically, but consider the special situation where the radius a of the loop of Fig. 1 is very small in comparison with both the wavelength $\lambda = 2\pi c/\omega$ and the distance r from the center of the loop to the point of interest P . We may then expand Eq. [5] as a function of a , for R is dependent on a . Furthermore, let us interpret the quantity $\pi a^2 I_0$ as an oscillatory magnetic moment m_x in the x direction that remains constant in amplitude in the limit as $a \rightarrow 0$. For second order in a (higher order terms tend to zero as a so tends) and after integration round the loop and some algebra, the electric field produced at P is given in spherical polar coordinates by

$$\begin{aligned} \mathbf{E}_{m_x} &= [E_r, E_\theta, E_\phi]_{m_x} \\ &= \left\{ i \left(\frac{\mu_0 m_x}{4\pi r^2} \right) \left(\omega + i \frac{r}{c} \omega^2 \right) e^{i\omega(t - \frac{r}{c})} \right\} \\ &\quad \times [0, \sin\phi, \cos\theta \cos\phi] \quad [6] \end{aligned}$$

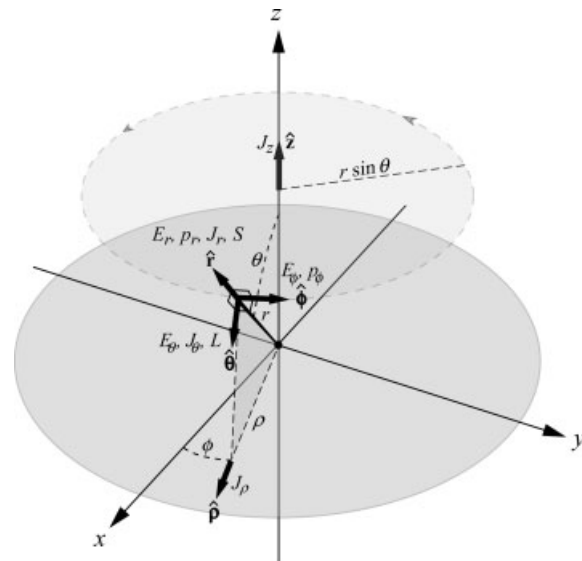

Figure 2 The principal unit vectors used in the article together with the various vectorial components employed.

The directions of the components of this and other vectors found in the article are shown in Fig. 2. Spherical polar coordinates are the “natural” coordinates of the system and particularly when we discuss angular momentum their use bypasses frequent problems in the literature associated with plane waves and Cartesian coordinates. Equation [6] is often seen in a more sophisticated format. If \mathbf{m} is a general vector magnet moment, then

$$\mathbf{E} = \left(\frac{\mu_0}{4\pi r^3}\right) \mathbf{r} \times \left(\frac{\partial[\mathbf{m}]}{\partial t} + \frac{r}{c} \frac{\partial^2[\mathbf{m}]}{\partial t^2}\right); \quad [7]$$

$$[\mathbf{m}] = \mathbf{m} \exp\left(i\omega\left[t - \frac{r}{c}\right]\right)$$

and the reader is urged to note, inherent in the plus sign in both equations, the summation of essentially two different terms having different frequency ω and distance r dependencies.

These expressions for \mathbf{E} are of interest because they directly lead to the electric field surrounding a precessing nuclear magnetic moment m and thus to the voltage across the terminals of a receiving coil. The moment can be interpreted as two equal, orthogonal, oscillatory magnetic moments m_x and m_y having a quadrature phase difference, and the resulting electric field for positive precession is given in Table 1 as Eq. [T1]; the electrostatic field associated with the nuclear charge q has been included for completeness. (Key equations are gathered in Table 1 for convenience.) Even though the origins of a nuclear magnetic moment reside not in the forced passage of electrical charge round a circuit but rather in a charge’s spin, there is no reason to suppose that Eqs. [6] and [7] do not apply to the bulk nuclear magnetic moment. Only when we consider the kinetic energy and momentum of motion will we have reservations; these may be associated with the omission of relativistic effects mentioned earlier.

Near and Far Fields—Experimental Results

If we place a loop of conductor in the yz plane, as shown in Fig. 1, the voltage ξ created across the loop gap by a rotating magnet m is given by the integral of the electric field round the loop, making due allowance, if necessary, for the propagation of the induced voltage round the loop at close to the speed of light (see problem 2, Appendix B.1.). Equivalently, and perhaps in a more familiar manner to NMR practitioners, it may be calculated from the Principle of Reciprocity (a general statement of

Lorentz’s principle of electromagnetic reciprocity may be found in Ref. 15, the near field NMR statement of the principle of reciprocity is in Ref. 16, the NMR generalisation of Ref. 16 is in Ref. 17, and problem 1, Appendix B.1.). However, in our current context, we now examine more closely the two dynamic constituents of Eq. [T1]. The first constituent, known as the *near* electric (strictly, “electrodynamic”) field, varies as ω/r^2 and is

$$\mathbf{E}^{\text{near}} = [E_r, E_\theta, e_\phi]^{\text{near}}$$

$$= \left\{ \left(\frac{m\mu_0}{4\pi r^2} \omega \right) e^{i\omega(t-\frac{r}{c})} \right\} [0, -e^{-i\phi}, i \cos\theta e^{-i\phi}] \quad [8]$$

The second constituent, known as the *far* electric field, varies as ω^2/cr and is

$$\mathbf{E}^{\text{far}} = [E_r, E_\theta, E_\phi]^{\text{far}}$$

$$= \left\{ \left(i \frac{m\mu_0}{4c\pi r} \omega^2 \right) e^{i\omega(t-\frac{r}{c})} \right\} [0 - e^{-i\phi}, i \cos\theta e^{-i\phi}] \quad [9]$$

Note the presence of the speed of light c in the denominator of this expression. We shall show later that this far field is associated with the emission of energy at the speed of light, in other words, radio waves. The ratio of the two fields is $c/\omega r$ or alternatively $\lambda/(2\pi r)$ or λ/r , where λ is known as the reduced wavelength. Thus if the circumference of the receiving loop, and by inference its radius r , is much less than wavelength λ , the near field at the loop is much larger than the far field—it is dominant because we are *near* the source—and the phase term $\omega r/c$ in the exponent of Eq. [8] can be neglected as it is small. This is generally the case in NMR spectroscopy though in ultra-high field imaging, the two fields may be comparable. In a meticulous set of crossed-coil, pulsed NMR experiments, Hoult and Ginsberg (6) tested the application of Eq. [7] at 64 MHz with a circular receiving loop, a sphere of water as an NMR sample and a loop radius such that $r/\lambda = 0.045$, which rendered the contribution of the far field negligible. They applied 90° pulses with the aid of the first (transmitting) coil and then, with that coil decoupled (blocked), measured the resulting signal voltage across the second (receiving) coil’s terminals with an RF voltmeter whose input impedance could be varied. In extrapolating their measurements of voltages across the coil terminals to the situation where the input impedance of the measuring device was infinite (i.e., an open circuit, as mandated in Operation 1 in the Introduction), they obtained an

Table 1 Key Equations (in spherical polar coordinates r, θ, ϕ)

The electric field in vacuo of a particle, with charge q and transverse magnetic moment m , rotating at frequency ω about the z axis:

$$\mathbf{E} = [E_r, E_\theta, E_\phi] = \left[\frac{q}{4\pi\epsilon_0 r^2}, 0, 0 \right] + \left\{ \left(\frac{m\mu_0}{4\pi r^2} \right) \left(\omega + \frac{i r \omega^2}{c} \right) e^{i\omega(t-\frac{r}{c})} \right\} [0, -e^{-i\phi}, i \cos\theta e^{-i\phi}] \quad [\text{T1}]$$

The magnetic field in vacuo of the particle:

$$\mathbf{B} = [B_r, B_\theta, B_\phi] = \left\{ \left(\frac{m\mu_0}{4c^2\pi r^3} \right) e^{i\omega(t-\frac{r}{c})} \right\} [2(c^2 + icr\omega) \sin\theta e^{-i\phi}, -(c^2 + icr\omega - r^2\omega^2) \cos\theta e^{-i\phi}, i(c^2 + icr\omega - r^2\omega^2)e^{-i\phi}] \quad [\text{T2}]$$

The electric field energy density:

$$\tilde{U}_E = \frac{\epsilon_0}{2} \langle \mathbf{E} \cdot \mathbf{E} \rangle = \frac{q^2}{32\pi^2\epsilon_0 r^4} + \frac{m^2\mu_0(1 + \cos^2\theta)}{64c^2\pi^2 r^4} \omega^2 + \frac{m^2\mu_0(1 + \cos^2\theta)}{64c^2\pi^2 r^2} \omega^4 \quad [\text{T3}]$$

The magnetic field energy density:

$$\tilde{U}_B = \frac{1}{2\mu_0} \langle \mathbf{B} \cdot \mathbf{B} \rangle = \frac{m^2\mu_0(5 - 3\cos^2\theta)}{64\pi^2 r^6} + \frac{m^2\mu_0(3 - 5\cos^2\theta)}{64c^2\pi^2 r^4} \omega^2 + \frac{m^2\mu_0(1 + \cos^2\theta)}{64c^4\pi^2 r^2} \omega^4 \quad [\text{T4}]$$

The combined energy density:

$$\tilde{U} = \frac{q^2}{32\pi^2\epsilon_0 r^4} + \frac{m^2\mu_0(5 - 3\cos^2\theta)}{64\pi^2 r^6} + \frac{m^2\mu_0\sin^2\theta}{16c^2\pi^2 r^4} \omega^2 + \frac{m^2\mu_0(1 + \cos^2\theta)}{32c^4\pi^2 r^2} \omega^4 \quad [\text{T5}]$$

The linear momentum density vector:

$$\tilde{\mathbf{p}} = \langle \mathbf{D} \times \mathbf{B} \rangle = [p_r, p_\theta, p_\phi] = \left[\frac{m^2\mu_0(1 + \cos^2\theta)}{32c^5\pi^2 r^2} \omega^4, 0, \frac{m^2\mu_0\sin\theta}{16c^2\pi^2 r^5} \omega + \frac{m^2\mu_0\sin\theta}{16c^4\pi^2 r^3} \omega^3 \right] \quad [\text{T6}]$$

In spherical polar coordinates (r, θ, ϕ) the elementary volume $dV = r^2 \sin\theta dr d\theta d\phi$ and

$$\text{curl} \mathbf{A} = \frac{1}{r \sin\theta} \left[\frac{\partial}{\partial\theta} (A_\phi \sin\theta) - \frac{\partial A_\theta}{\partial\phi} \right] \hat{\mathbf{r}} + \frac{1}{r} \left[\frac{1}{\sin\theta} \frac{\partial A_r}{\partial\phi} - \frac{\partial}{\partial r} (r A_\phi) \right] \hat{\boldsymbol{\theta}} + \frac{1}{r} \left[\frac{\partial}{\partial r} (r A_\theta) - \frac{\partial A_r}{\partial\theta} \right] \hat{\boldsymbol{\phi}} \quad [\text{T7}]$$

where $\hat{\mathbf{r}}, \hat{\boldsymbol{\theta}},$ and $\hat{\boldsymbol{\phi}}$ are unit vectors in the directions of increasing $r, \theta,$ and $\phi,$ respectively.

In cylindrical polar coordinates (ρ, ϕ, z) the elementary volume $dV = \rho d\rho d\phi dz$ and

$$\text{curl} \mathbf{A} = \left[\frac{1}{\rho} \frac{\partial A_z}{\partial\phi} - \frac{\partial A_\phi}{\partial z} \right] \hat{\boldsymbol{\rho}} + \left[\frac{\partial A_\rho}{\partial z} - \frac{\partial A_z}{\partial\rho} \right] \hat{\boldsymbol{\phi}} + \frac{1}{\rho} \left[\frac{\partial}{\partial\rho} (\rho A_\phi) - \frac{\partial A_\rho}{\partial\phi} \right] \hat{\mathbf{z}} \quad [\text{T8}]$$

where $\hat{\boldsymbol{\rho}}, \hat{\boldsymbol{\phi}},$ and $\hat{\mathbf{z}}$ are unit vectors in the directions of increasing $\rho, \phi,$ and $z,$ respectively.

For a particle having rest mass $M,$ linear momentum p and energy $U,$ $U^2 = p^2 c^2 + M^2 c^4.$ Hence for *real* photons with $M = 0,$ $U = pc.$ If the photonic momentum per unit volume is $\tilde{\mathbf{p}},$ the energy per unit volume is $|\tilde{\mathbf{p}}|c,$ and the power flow per unit area $\mathbf{W} = c^2 \tilde{\mathbf{p}}$

agreement between theory and experiment of better than 1%—and also removed the perturbation caused by the observer and her apparatus. If there were any doubts, their result proves that classical electromagnetism can accurately predict the MR signal strength

induced in an open-circuit coil and that the contribution of radio waves in their experiment was negligible. In turn, as a valid quantum theory must also agree with experiment, Dicke's theory of coherent spontaneous emission cannot explain the results, as

discussed in more detail later. The dominant *near* electric field, having a linear frequency dependence and an inverse square dependence on distance, is an expression of Faraday's law of induction: when integrated round the loop, we obtain the induced voltage. Remembering that nuclear magnetization is proportional to field strength and therefore Larmor frequency, it is of interest to note that in a (rare) situation in which the far field (i.e., coherent spontaneous emission) is a major contributor to the NMR signal, that contribution is proportional to ω^3 (*q.v.*). However, NMR spectroscopy has never been in this desirable state and has had to be content with the squared law dependence of Faraday induction, as is well known. MRI will approach this nirvana with the B_0 field of 11.7 T proposed at various sites, but to satisfy the eponymous Capt. Murphy, the implementation will have numerous difficulties.

Energy and Momentum in Fields

By rights, discussion could end at this point unless by some stretch of the imagination the near field could be construed to be part of a radio wave (see later). We have a classical phenomenon accurately described by a classical theory that has been validated by experiment, and it shows that for water, and by extension many other NMR scenarios, the signal is due overwhelmingly to the near electric field, not the far field, a.k.a. radio waves. Because of errors in the past, however, we should examine the quantum mechanics of the situation. More importantly though, it is highly unsatisfactory to have a body of quantum mechanical descriptions that illuminate the nooks and crannies of the NMR discipline, only to falter on one of the most fundamental aspects of the phenomenon. This is particularly so when one wishes for an integrated description of the signal from NMR phenomena that can *only* be described by quantum mechanics. The author therefore tries (for near-field interactions are the *bête noire* of quantum electrodynamics) to make progress in this area and as a prelude, we consider the energy and momentum of electromagnetic fields—a rather intriguing branch of physics that to this day has problems. We shall see here further strong evidence of the distinct natures of near and far fields.

It is noteworthy that the derivation of all equations so far has not involved energy in any manner. Rather, starting with Coulomb's Law and Special Relativity, we have dealt exclusively with *forces* working at a distance. However, there *is* energy in electromagnetic fields, but to access it mathematically we must know the magnetic fields \mathbf{B} in addition to the electric fields

\mathbf{E} . Their full expression is given in Table 1. \mathbf{B} may be derived from first principles in the manner used for the derivation of \mathbf{E} , or alternatively, its dynamic components may be had from Eqs. [2] and [7]:

$$\begin{aligned} \mathbf{B} &= - \int \text{curl} \mathbf{E} dt \\ &= \text{curl} \left\{ \left(\frac{\mu_0}{4\pi r^3} \right) \mathbf{r} \times \left([\mathbf{m}] + \frac{r}{c} \frac{\partial [\mathbf{m}]}{\partial t} \right) \right\} \end{aligned} \quad [10]$$

Now it is shown in all texts on electrodynamics that the total mean energy density in real electromagnetic fields *in vacuo* is given by (e.g., 10, p 236)

$$\tilde{U} = \frac{1}{2\mu_0} \left\langle \frac{\mathbf{E} \cdot \mathbf{E}}{c^2} + \mathbf{B} \cdot \mathbf{B} \right\rangle \quad [11]$$

and the temporally averaged components of this equation are shown in Table 1 as Eqs. [T3–T5]. (A tilde will be used to indicate volume densities.) Integrating over a spherical surface to obtain the total energy in a shell of unit thickness, we obtain

$$U_{\text{shell}} = \frac{q^2}{8\pi\epsilon_0 r^2} + \frac{m^2 \mu_0}{4\pi r^4} + \frac{m^2 \mu_0 \omega^2}{6\pi c^2 r^2} + \frac{m^2 \mu_0 \omega^4}{6\pi c^4} \quad [12]$$

Note that we have included as the first two terms the frequency-independent electrostatic and magneto-static energies. Feynman (9) gives a presentation of the arguments (due to Poynting) for believing that some of the energy is flowing and further that there is momentum in the fields, and the reader is urged to read his chapters 27 and 28. Accordingly, following Minkowski (however, see 10, p 240) we consider the *free-space* vector

$$\tilde{\mathbf{p}} = \frac{1}{\mu_0 c^2} \langle \mathbf{E} \times \mathbf{B} \rangle = \epsilon_0 \langle \mathbf{E} \times \mathbf{B} \rangle = \langle \mathbf{D} \times \mathbf{B} \rangle_{\text{free space}} \quad [13]$$

to be linear momentum density. After some algebra, we find in spherical polar coordinates the expression for $\tilde{\mathbf{p}}$ given in Eq. [T6]. This equation contains a wealth of information and intrigue, not the least of which is that there are two components of momentum p_ϕ flowing in a circular (azimuthal) direction about the z axis, see Fig. 2.

Consider first the radial flow p_r . As this outward momentum must be moving at the speed of light, we may tentatively identify it with photons and multiply by c to obtain the energy density (see the footnote of Table 1). This gives us the final term in the energy density Eq. [T4], thereby confirming our identifica-

tion. The associated radial energy in a shell of unit thickness is

$$\begin{aligned}
 U_{\text{shell}}^{\text{far}} &= \int_{dr=1} c p_r dV = \int_{\phi=0}^{2\pi} \int_{\theta=0}^{\pi} p_r c r^2 \sin\theta \, d\theta d\phi \\
 &= \frac{m^2 \mu_0 \omega^4}{6\pi c^4} \quad [14]
 \end{aligned}$$

the final component of the shell energy in Eq. [12], and multiplying by c , we obtain for future use the radiated power

$$W_r = \frac{m^2 \mu_0 \omega^4}{6\pi c^3} \quad [15]$$

We have just illustrated a direct relationship between the far linear momentum and the radiated energy of a precessing magnetic moment. However, when we apply the same treatment to the azimuthal momentum p_ϕ , it is quite clear that it cannot be considered to be an energy flow, for not only does it not radiate (i.e., move out in a radial pattern) but with its odd order frequency dependencies it has no corresponding terms in Eq. [12].

Let us return to the enigmatic p_ϕ later. If we examine Eq. [T2] in Table 1 for the alternating magnetic fields \mathbf{B} of our precessing magnetic moment, we see that every term varies as r^{-n} where $n = 1, 2, \text{ or } 3$. (There is r^{-3} at the front of the equation.) Thus it is impossible for the radial momentum p_r —a product of E and B with r^{-2} dependence—to originate with the near electric field of Eq. [8], for \mathbf{E}^{near} varies as r^{-2} . Rather, it must come from the far electric field of Eq. [9] that is proportional to ω^2/r . This realization immediately narrows the range of magnetic fields that contribute to p_r ; they too must vary as ω^2/r . Thus, for a precessing magnetic moment we obtain from Eq. [T2]

$$\begin{aligned}
 \mathbf{B}^{\text{far}} &= [B_r, B_\theta, B_\phi]^{\text{far}} \\
 &= \left\{ \left(\frac{m\mu_0 e^{-i\phi}}{4c^2 \pi r} \omega^2 \right) e^{i\omega(t-\frac{r}{c})} \right\} [0, \cos\theta, -i] \quad [16]
 \end{aligned}$$

Looking at Eqs. [9] and [16], whereas \mathbf{E}_{far} and \mathbf{B}_{far} are both self-evidently orthogonal to p_r (neither is in the radial direction), it is readily apparent by taking their scalar product that they are also orthogonal to one another. This structure is that of the classic radio wave that can be found in any standard electrodynamics text, and in the limit as the ratio of the radius to the wavelength tends to infinity, so these waves can be considered the plane waves beloved of such texts. It is left as an exercise to the reader

(problem 4, Appendix B.1.) to show that the radial momentum vector obtained from Eqs. [9] and [16] is the same as that previously calculated. Note that the ratio $|\mathbf{E}^{\text{far}}|/|\mathbf{B}^{\text{far}}|$ is simply c , the speed of light, a characteristic of far fields that reflects the fact that \mathbf{E}^{far} and \mathbf{B}^{far} are two sides of the same relativistic coin (see problem 5, Appendix B.1.).

The electric and magnetic fields that fall off more rapidly than $1/r$ play no part in the radiative process but as alluded to above, it is sometimes erroneously thought that the appellation “radio waves” somehow encompasses these fields and that the division into near and far is somehow artificial or merely semantic. However, the relative sizes of the near and far fields are dependent on the generator’s characteristics; for example, it is well known that our results for \mathbf{E} and \mathbf{B} are interchanged when the fields from an oscillating electric dipole are calculated (10, p 398). Thus it is valid, and indeed the usual practice, to draw a near/far field distinction and we have already seen that in most NMR experiments it is the near electric field that is overwhelmingly responsible for the free induction decay voltage.

Let us now examine the azimuthal flow p_ϕ in Eq. [T6]. If we were to have used in its calculation only the far electric field \mathbf{E}^{far} , with its $1/r$ dependency, we would have obtained only that portion of p_ϕ in Eq. [T6] that varies as ω^3 , viz

$$p_\phi^{\text{far}} = \frac{m^2 \mu_0 \omega^3 \sin\theta}{16c^4 \pi^2 r^3} \quad [17]$$

(Note that with its r^{-3} dependency, it arises from that portion of \mathbf{B} in Eq. [T2] that varies as r^{-2} .) It follows that via their common \mathbf{E}^{far} field, this momentum must be linked in some way with the radiated power and the far energy density. To forge the link, consider the *angular* momentum about the z axis associated with p_ϕ^{far} . In a shell of unit thickness it is

$$\begin{aligned}
 J_{z,\text{shell}}^{\text{far}} &= \int_{\theta,\phi,dr=1} p_\phi^{\text{far}} r \sin\theta \, dV \\
 &= \int_0^\pi \frac{m^2 \mu_0 \omega^3 \sin\theta}{16c^4 \pi^2 r^3} 2\pi r^3 \sin^2\theta \, d\theta = \frac{m^2 \mu_0 \omega^3}{6\pi c^4} \quad [18]
 \end{aligned}$$

The ratio of this quantity to the shell energy $U_{\text{shell}}^{\text{far}}$ of the radio waves in Eq. [14] is simply ω with no radial dependence, and this result is often portrayed as the equivalent of the well-known quantum mechanical result that a photon of energy $U = \hbar\omega$ has a spin $S = 1$ with angular momentum $\hbar = U/\omega$. However,

we shall see later that the truth is more subtle, for example, the ratio $dU^{\text{far}}/dJ_z^{\text{far}}$ for an elementary ring at declination θ is certainly not ω , for $dU^{\text{far}}/d\theta$ (from Eq. [T5]) varies as $(1 + \cos^2\theta) \sin^2\theta$ whereas $dJ_z^{\text{far}}/d\theta$ in Eq. [18] varies as $\sin^3\theta$. (For a discussion of the problems of angular momentum in plane waves, see Ref. 18. Much angst is avoided by working, as we have done here, with spherical waves rather than the somewhat artificial construct of plane waves.)

We have one momentum term unaccounted for: the residue of p_ϕ or p_ϕ^{near} . It is associated with \mathbf{E}^{near} and when, like p_ϕ^{far} , it is considered as a measure of angular momentum, the amount in a shell of unit thickness is (see problem 6, Appendix B.1.)

$$J_{z,\text{shell}}^{\text{near}} = \frac{m^2 \mu_0 \omega}{6c^2 \pi r^2} \quad [19]$$

With its r^{-2} dependence, this is clearly local to the precessing magnetic moment (c.f. Eq. [18]). However, whereas we have associated the angular momentum of p_ϕ^{far} with the radiated energy in a manner that is independent of radius, we have no such options for p_ϕ^{near} . Apparently, it must be associated with local or *stored* energy in Eq. [T5]. Subtracting the radiated energy $U_{\text{shell}}^{\text{far}}$ from U_{shell} we obtain

$$U_{\text{shell}}^{\text{static}} + U_{\text{shell}}^{\text{near}} = \frac{q^2}{8\pi\epsilon_0 r^2} + \frac{m^2 \mu_0}{4\pi r^4} + \frac{m^2 \mu_0 \omega^2}{6c^2 \pi r^2} \quad [20]$$

This energy comprises the static energy stored in the electric and magnetic fields about a charged magnetic moment, and a near dynamic term in ω^2 associated with the nuclear precession. Taking this latter term, we find as for the far fields that $U_{\text{shell}}^{\text{near}}/J_{z,\text{shell}}^{\text{near}} = \omega$, with an implication of photons, even though the energy is localized and not radiated. This perplexing relationship will be further examined later.

In passing, most elementary texts interpret the Poynting vector $\mathbf{N} = \mathbf{E} \times \mathbf{B}/\mu_0$ as a measure of energy flow; probably because they usually only consider the far field terms. However, this is clearly misleading and we have seen *in vacuo* that it is better if we consider the vector

$$\begin{aligned} \tilde{\mathbf{p}} &= \frac{\mathbf{N}}{c^2} = \frac{1}{\mu_0 c^2} \langle \mathbf{E} \times \mathbf{B} \rangle = \epsilon_0 \langle \mathbf{E} \times \mathbf{B} \rangle \\ &= \langle \mathbf{D} \times \mathbf{B} \rangle_{\text{free space}} \end{aligned} \quad [21]$$

to be linear momentum density. Then the energy density in the radio waves is their linear momentum density times their velocity or $U_r = cp_r$.

THE CORRESPONDENCE PRINCIPLE AND QUANTUM MECHANICS

History

Having set the stage by calculating electromagnetic energy and momentum and describing the interior relations between them, we now turn to a quantum mechanical approach. Quantum mechanics deals with the quantisation of energy and momentum within a theoretical framework usually built around the Lagrangian and Hamiltonian approaches to mechanics, and one of the foundation stones of the discipline was Bohr's Correspondence Principle. The author can do no better than to quote (8, p 105) Nobel Laureate Max Born's 1933 statement on the subject: "Judged by the test of experience, the laws of classical physics have brilliantly justified themselves in all processes of motion, macroscopic and microscopic, down to the motion of atoms as a whole (kinetic theory of matter). It must therefore be laid down, as an unconditionally necessary postulate, that the new [quantum] mechanics, supposedly still unknown, must in all these problems reach the same result as the classical mechanics. In other words, it must be demanded that, for the limiting cases of large masses and of orbits of large dimensions, the new mechanics passes over into classical mechanics." (Note that the author is not invoking a more modern definition of the Principle wherein Planck's constant $h \rightarrow 0$ is asserted to generate a "classical limit." Bohr himself, in a conversation with Purcell, objected to a blanket use of this device (Ref. 19 together with other relevant papers may be found online at <http://philsci-archive.pitt.edu/>. Accessed 2009).

An NMR sample of water surely falls into the category of a large mass when compared with the mass of a hydrogen atom, and thus to use a modern idiom, we can emphatically state that as, for the simple example of the signal from a few milliliter of H_2O we have a classical description that agrees with experiment, "classical physics rules." Only when we try to interpret more complex phenomena, such as J-couplings or the dynamics of spin-7/2 nuclei, do we require a quantum approach. The tendency in NMR circles to feel that everything must be expressed as a Hamiltonian to be "proper science" is regrettable, as it sometimes creates unnecessary complexity in which a simpler classical description has value: if that classical description agrees with experiment, it may provide a touchstone for a quantum theory and nowhere is this needed more than in an analysis of signal reception.

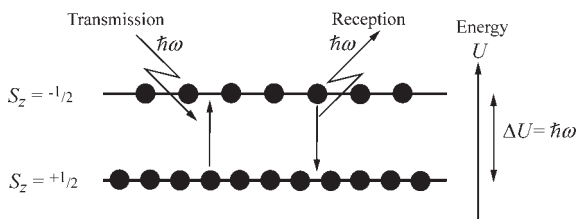

Figure 3 A naïve interpretation of the process of NMR transmission and signal reception wherein the emitted photons are responsible for the free induction decay.

That having been said, the early pioneers of NMR were perplexed when they attempted to understand NMR signal reception on a quantum level, for it appeared that quantum mechanics gave a false result. In the middle of the last century, thanks to the work of Einstein, only three classes of interaction between electromagnetic energy (radio waves in our context) and matter were known: absorption, stimulated emission, and spontaneous emission. Only in Feynman’s fertile imagination was a fourth mechanism—near field interaction via photons with the “wrong” energy (see later)—taking shape. It was felt that Einstein’s three concepts had to be applicable to an apparently simple two-level NMR system: to wit during transmission, the system absorbs photons and there are upward transitions to the higher energy level; during reception photons are emitted and there are downward transitions, as shown in Fig. 3. Accompanying each transition is a corresponding change of angular momentum \hbar that is brought or carried away by a photon. What could be simpler and who has not seen this picture in countless elementary texts on MRI? A major difficulty with it, however, is well expressed in a 1968 article by Macomber (20): “The fact that the signal persists after the irradiation from the transmitter ceases is another proof that neither absorption nor stimulated emission is involved. It therefore follows that the signal produced in a crossed-coil NMR spectrometer must be due to spontaneous emission. However, it must be a very strange kind of spontaneous emission: Bloembergen and Pound computed the half-life of an NMR excited state that one should expect to be associated with this relaxation mechanism. For a proton in a magnetic field of 10^4 oersteds [1 T], it turns out to be 10^{25} seconds—about 10^8 times the estimated age of the universe.” (In a crossed-coil spectrometer, spectra are acquired by driving a first coil and receiving signal in a second coil.)

The probability of spontaneous emission P_0 of a photon from an ensemble of N spin-1/2 magnetic moments in free space is (21)

$$P_0 = N \frac{\mu_0 \omega^3 \gamma^2 \hbar}{6\pi c^3} \quad [22]$$

which translates to 0.024 photons per second at 1 T for a 1 ml sample of water, a very small number. Here γ is the magnetogyric ratio of protons and \hbar is Plank’s constant divided by 2π .

The reader should note the shift in emphasis in the thinking here. We have moved from concepts of force (i.e., electric fields) to quantum concepts of energy, and this duality has existed since the earliest days of NMR. Felix Bloch thought classically in terms of “an induced electromotive force in a coil, due to the precession of the nuclear magnetic moments” (22)—he excluded an observer—whereas Ed Purcell was concerned with absorption of energy in a continuous wave experiment and the coupling of energy between the NMR system and a tuned cavity (23)—he included an observer. Erwin Hahn, in an article describing the first pulse experiment (24), adroitly mixes the two concepts. He first relates the Bloch prediction of what we would now call a free induction decay (FID), then states that “Only a single LC tuned circuit is essential for transmitting and receiving r-f energy” and finally shows an FID. This statement will be thoroughly questioned later for it injects into the description a very particular and disruptive observational apparatus that drives the analysis.

It is probably true to say that Purcell’s preoccupation with the energetics of NMR influenced a succession of researchers and none more so than Robert Dicke. Dicke and Purcell worked together during the Second World War on the development of radar at the Massachusetts Institute of Technology and in 1953, Dicke, having moved to Princeton University, published a seminal paper entitled “Coherence in Spontaneous Radiation Processes” (4) in which he referred to the articles by Bloch and Hahn cited earlier. Here, quoting another important article on the subject by Tavis and Cummings (25), Dicke treated “a gas of radiating molecules as a single quantum system, in that the molecules are interacting with a common radiation [*sic*] field and should not be treated as independent. An independent molecule picture is wrong in principle as are many results obtained from it.” The result of considering these multiple *near-field* interactions was dramatic—an increase of emission probability by a factor

$$C = \frac{N}{4} \left(\frac{\hbar\omega}{2kT} \right)^2 \quad [23]$$

or for our 1 ml water sample in a field of 1 T, a factor of 2×10^{11} .

One can imagine the sigh of relief that must have circulated, for it must have been transparently clear to everyone that this solved the problem. To return to Macomber's article, written 14 years after Dicke's analysis, he finishes by saying "In conclusion, it has been shown that a crossed-coil NMR spectrometer [read also 'pulse spectrometer'] is a unique kind of instrument, operating not by absorption, spontaneous emission or stimulated emission of radiation in the usual fashion. Rather, the signal is produced by coherence brightened spontaneous emission, due to the special phase relationship between the magnetic moments of the nuclei." Rosenthal (26) had minor disagreements with Macomber (27) but Dicke (28) finished the discussion by tactfully concluding that both Macomber and Rosenthal were correct. In other words, it was now generally accepted that the NMR signal was due to radio waves, which are coherent radio frequency emission of photons.

Discussion

Dicke was a giant in the physics of the latter half of the twentieth century and his article was undoubtedly brilliant. It, together with the article by Hahn, encouraged many other researchers to consider the NMR system as one quantum entity interacting with a tuned cavity or circuit for which, of course, a Hamiltonian can be written (an example is Ref. 29). [In hindsight though, this created an entirely new quantum entity (5) of phenomenon + observer.] However, the author must ask the reader to step back and ask difficult questions: What exactly has Dicke predicted and why is there a preoccupation with, in Hahn's word, an "essential" LC tuned circuit? Looking at the first question, we note that the magnetic moment of N protons is (20)

$$m = \frac{N\gamma\hbar^2\omega}{4kT} \quad [24]$$

We now take Eqs. [22] to [24] and knowing that the energy carried by a photon is $\hbar\omega$, calculate the emitted energy in terms of nuclear magnetic moment m . It is left as an exercise to the reader to show that the result is exactly that calculated classically in Eq. [15], i.e., W_r . Dicke had calculated the power carried away in radio waves from an uncoupled, free-standing NMR sample to which a 90° pulse had been applied.

Here, a sophisticated quantum mechanical energy calculation has given the same result as a classical calculation—the Correspondence Principle has been

fulfilled and the emission of radio waves has been correctly predicted. However, it is only a partial result, for the calculation has not revealed the azimuthal component of the momentum flow in Eq. [T6] nor has it even hinted at the near field portions of Eq. [T1] that account for the vast majority of the NMR signal induced in an open-circuit coil. (The reader is strongly reminded that the near field is not coupled to the far field radio waves—its size and characteristics depend on its origins—magnetic moment, electric dipole, etc.) In other words, although Dicke's *calculation* is undoubtedly correct, his and Macomber's *assumption* that the NMR signal is explained is incorrect in that it disagrees profoundly with experiment. Richard Feynman, another Nobel Laureate, criticized succinctly the quantum context found here (30): "The Hamiltonian method is not well adapted to represent the direct action at a distance between charges because that action is delayed." At fault too are those who gladly accepted the explanation without ever putting it to the test. A simple "back of the envelope" estimation using the radiated power could have given the order of magnitude of the voltage it supposedly induces in a coil. Consider a receiving coil of radius b encompassed by a sphere of the same radius. The Poynting vector's mean magnitude is the power W_r derived above divided by the surface area of the sphere, and that magnitude is well known (31) (see also earlier) to be $E^2/2Z_0$ where E is the electric field *amplitude* and Z_0 , the characteristic impedance of space, is $c\mu_0$. On the simple (albeit inaccurate) assumption that the power is radiated uniformly, it is only a couple of lines of algebra to show that the electric field E (c.f. Eq. [9]) and coil voltage ξ are

$$E \sim \frac{m\mu_0\omega^2}{\sqrt{12c\pi b}}; \quad \xi \sim \frac{m\mu_0\omega^2}{\sqrt{3c}} \quad [25]$$

These results are found not only to be seriously in error in their orders of magnitude (6), they are also wrong both in their spatial and frequential dependencies, yet apparently no one performed this simple check until recently. Although, in the early days of NMR there was not a large body of measurements at different field strengths with which to question frequency dependence, it was certainly possible to vary the receiving coil size and it was known both intuitively and practically that the "filling factor" of a receiving coil was important (20).

Turning to the second question, it is important to realize that the assertion of the role of coherent spontaneous emission was due mainly to analysis of the NMR phenomenon when coupled strongly to a par-

ticularly unfortunate observational apparatus—a simple LC circuit (5). It was *not* for an open-circuit coil. This apparatus allowed the induced near-field e.m.f. ξ to initiate maximal current flow $I = \xi/R_s$ proportional to the inverse of small circuit resistance R_s with large deposition of power ξ^2/R_s . Concomitantly, the ensuing near B_1 field induced nuclear transitions (so called “radiation” damping, though the interactions are near-field) to account for the transfer of energy to the LC circuit’s resistance. The mechanism of coherent spontaneous emission, enhanced by the Q-factor of the coil, was then invoked to account for that transfer of energy—the energy books had to be balanced. However, no explanation was given as to how the enhanced radiation, that should have proceeded freely out into space (Eq. [9]), could somehow be subverted by a tuned circuit such that the energy in that radiation was totally absorbed by the tuned circuit’s resistance. Although there is certainly emission and transfer of energy, it cannot be the energy of radio waves. Another unfortunate part of the analysis was that, as the noise power in signal reception is proportional to R_s , a seductive link was noted between signal-to-noise ratio and “radiation” damping. However, this is an observer-induced relationship associated with a particular observational device that happens to be highly coupled and it is strongly emphasized that the relationship is not generally applicable to a noise-matched situation. “Radiation” damping is not a predictor of signal-to-noise ratio.

It is stressed once again that an LC circuit is not required to observe the NMR voltage nor is it the best way to do it: the electromotive force induced in a coil can be detected and measured without that coil being in parallel with a capacitor. Indeed, in general, induced voltages are usually measured with little perturbation simply by placing a high-impedance voltmeter or oscilloscope directly across a coil without the aid of any tuning, albeit with suboptimal signal-to-noise ratio. The author would respectfully suggest that LC circuits are used in formal quantum mechanical calculations simply because they render an energy calculation tractable (a Hamiltonian can be written but it includes the observer) and because they are part of the folklore of NMR on which theoreticians gratefully seize. It is now known (32–34) that an LC circuit is the worst possible observational method as it maximizes the power absorbed from the NMR system. Instead, that power can be minimized by suitable engineering while maintaining S/N (see Appendix A.2.). As previously described, Hoult and Ginsberg (6) deliberately set out to measure with an RF voltmeter, across the terminals of an untuned coil, the FID voltage ξ at 64 MHz from a ping-pong ball

filled with water. The input resistance R_{in} of the voltmeter could be varied and not surprisingly, they found that the measured voltage V was determined by the potential divider comprising R_{in} and the coil reactance; in other words, if $i = \sqrt{-1}$,

$$V = \frac{R_{in}}{R_{in} + i\omega L} \xi \quad [26]$$

where L is the coil inductance. From the fit to the data, ξ was found and as we have remarked earlier, it agreed with classical electromagnetics, the bulk nuclear magnetic moment having been calculated from the quantum formula of Eq. [24]. They essentially removed the perturbing role of the observer by a well-accepted extrapolation from an observable situation to one that is not observable using time-honoured electronics theory.

The Copenhagen Interpretation of Quantum Mechanics

The above is elementary electronics theory, albeit difficult to implement practically, but it is worth taking a short philosophical digression as it impinges in an interesting manner on the uneasy ceasefire (19) known as the Copenhagen interpretation (CI) of quantum mechanics (19, 35). Clearly, for an observation to be made and the voltmeter to record a number, energy has to be absorbed from the nuclear system, the amount being determined by the variable input resistance R_{in} . However, as that input resistance tends to infinity, so the energy required becomes less and less. Of course, there comes a point at which current technology imposes a limit on the resistance and a voltage can no longer be measured. Does this mean that from this point on the induced e.m.f. ξ is a figment of our imagination—it has no independent existence? Quoting Cramer (36) in a discussion about the CI: “Wheeler . . . has been led to assert the often quoted paradigm: ‘No phenomenon is a phenomenon until it is an observed phenomenon.’ In this statement he is emphasizing the role of the observer in precipitating an underlying indefinite reality [e.g., an electromotive force, e.m.f.] into a definite observed state [e.g., a measured voltage] by the act of deciding on a measurement and then performing it.” However, Cramer also writes “While participating in a colloquium at Cambridge, von Weizsäcker (1971) denied that the CI asserted: ‘What cannot be observed does not exist.’ He suggested instead that the CI follows the principle: ‘What is observed certainly exists; about what is not observed we are still free to make suitable assumptions. We use that freedom to avoid

paradoxes.’ This principle does not, of course, uniquely define the CI, but it does give an important criterion for developing a consistent interpretation of a [quantum mechanical] formalism.” [The author’s insertions.] Any electrical engineer would clearly side with von Weizsäcker as the concept of an e.m.f. has been a valuable fixture in electrical theory for more than a century and a half—even when it cannot be measured. It provides an exceptionally firm basis for the removal of the observer. The interface between measurement, classical, and quantum theory is troubled to this day, and a good overview may be found in the writings of Landsman (19).

The Far Rotational Momentum

To summarize our understanding to this point, classical physics predicts that a precessing nuclear magnetic moment creates forces (electric fields) on adjacent charges (the electrons in a receiving coil). Those forces are of two types, near and far, and allied with the far type is an outward flow of energy (radio waves). This outward flow is associated with nuclear Zeeman energy level transitions and can be accurately predicted by both classical electrodynamics and quantum mechanics. However, the outward flow does not account for the voltage induced in an open-circuit receiving coil and Dicke’s quantum calculation sheds little light on the rotational component of the momentum vector, the associated energy and their connection to that received signal. Let us therefore bring the far field quantum picture to a close with a final analysis. In so doing, we tread outside the usual textbook content. The reason for the analysis is to explore concepts that both further highlight the differences between near and far fields and also give a starting point for a near field quantum understanding—Feynman’s fourth mechanism. The reader is cautioned that from this point on, much of the article is speculative, and in its difficulties and implications, highlights the fact that the quantum physics of near field phenomena is uncertain and unfinished.

The basic quantum mechanics of a spin-1/2 NMR system asserts that with each energy level transition that releases a photon of energy $\hbar\omega$, there is also a change of spin from $S_z = -1/2$ to $S_z = +1/2$ which releases an angular momentum of $J_z^{\text{far}} = -\hbar$ in the z direction. Neglecting the minus sign (in the spirit of the convention in NMR of neglecting the minus sign in the Larmor equation $\omega_0 = -\gamma\mathbf{B}_0$ and considering positive precession), we therefore assume from this relationship that there is an angular momentum density in the emitted radio waves/photons that from the final part of Eq. [T5] is given by

$$\tilde{\mathbf{J}} = \frac{\tilde{U}^{\text{far}}}{\omega} = \frac{m^2\mu_0\omega^3(1 + \cos^2\theta)}{32c^4\pi^2r^2}\hat{\mathbf{z}} \quad [27]$$

where $\hat{\mathbf{z}}$ is the unit vector in the z direction. Note that it is the *source* that is determining the angular momentum content of the photons; it is not predetermined by a particular photon property. We have already seen that the integral of this value agrees with that obtained from the circulating azimuthal momentum vector p_ϕ^{far} of Eq. [T6] and that it is associated by some with photon spin. Let us now, however, look at the problem mentioned earlier—the declinational relationship of J_z^{far} and p_ϕ^{far} . Consider a region of space that holds numerous systems of localized circulating linear momenta and that carries in consequence an angular momentum density $\tilde{\mathbf{J}}$. (A physical example would be multiple solar systems.) It is shown in Appendix A.1. that for the approximation of a continuous distribution of systems, and as the spatial extent of a system tends to (but is not) zero, there is, through the selected region of space, a net flow of *linear* momentum whose density is given by

$$\tilde{\mathbf{p}} \simeq \text{curl}\tilde{\mathbf{J}}/2 \quad [28]$$

Let us therefore use this relationship in an attempt to derive p_ϕ^{far} from J_z^{far} . (We may imagine that we are so far from the precessing nuclei that the emitted photons are essentially particles with *relatively* tiny spatial extent cT_2 , where T_2 is the transverse relaxation time of the NMR system.) Surprisingly, we obtain an incorrect result (c.f. Eq. [T6]):

$$p_\phi = \frac{m^2\mu_0(3\sin\theta + \sin 3\theta)}{64c^4\pi^2r^3}\omega^3 \neq p_\phi^{\text{far}} \quad [29]$$

which is presumably why this derivation is not attempted in texts on electromagnetism. A possible explanation is that so far we have ignored the fact that photons may, in addition to spin, also carry so-called orbital angular momentum (a very misleading name taken from analogies with atomic physics—what is orbiting what?) perpendicular to the direction of travel. Photon orbital angular momentum remained in relative obscurity until recently when a detection method was published (37) and it was realized that information could be encoded in it. Working temporarily in *cylindrical* polar coordinates, where the curl function gives an azimuthal resultant from both axial (z) and radial (ρ) inputs (see Fig. 2 and Eq. [T8]), let us add a cylindrically radial angular momentum density $J_\rho(\rho, z)\hat{\rho}$ to $J_z\hat{\mathbf{z}}$, where $\hat{\rho}$ and $\hat{\mathbf{z}}$ are unit vectors. (These two components of angular

momentum may, of course, be resolved into J_r and J_θ in spherical polar coordinates, in other words, spin and orbital angular momenta.) The sum additional angular momentum J_ρ is zero when integrated over a spherical shell, so we have not violated the principle of conservation of angular momentum. Then taking the azimuthal component of curl $[J_\rho, 0, J_z]/2$ and setting it equal to p_ϕ^{far} , we may obtain an expression for $\partial J_\rho/\partial z$. We may then integrate this expression to obtain J_ρ . Annoyingly, the result is nonphysical, tending to infinity along the z axis, so the addition of orbital angular momentum appears not to help in correcting Eq. [29]. The inescapable conclusion is that in electromagnetism, Eq. [28] is incorrect. However, if the right hand side of that equation is multiplied by a factor α , a plausible result is obtained for, and only for, $\alpha = 4/3$, and readers may wish to ascertain this for themselves (problem 8, Appendix B.1.). Then reverting to spherical polar coordinates we have

$$\tilde{\mathbf{J}} = [J_r, J_\theta, J_\phi] = \left(\frac{m^2 \mu_0 \omega^3}{32c^4 \pi^2} \right) \left[2 \frac{\cos\theta}{r^2}, -\frac{\sin\theta}{r^2}, 0 \right] \quad [30]$$

and it may be verified that the z component is the \tilde{J} of Eq. [27]. The author is tempted to say that this result is such an elegant and simple vectorial decomposition of J_z that it must be correct, and indeed corroborating evidence is given later. (A sobering counter-example to this mindset is described in Appendix A.2. where the supposed relationship between “radiation” damping and S/N is discussed.) Lest the reader thinks, however, that the author is playing the magician pulling factors out of a hat, the factor of $\alpha = 4/3$ is not novel; it famously has had a long and annoying history in classical electromagnetism, first being encountered in the context of electromagnetic mass (see later) by Thomson in 1881. It is generally considered to be a relativistic correction to momentum and energy first proposed by Fermi at the age of 21 in 1922 (38). It would appear that this factor is also relevant to *our* situation, though the author has been unable to prove this. We shall pursue the topic no further as it would take us into deep waters, but the interested reader is referred to an excellent educational paper by Moylan (39) and should contrast it with Feynman’s approach (9, Ch. 28). Chapter 17 of Jackson (10) is also of interest.

We see that if Eq. [30] is correct, the radiated energy carries both radial and declinational angular momenta: in quantum terminology, spin $S \propto J_r$ and orbital angular momentum $L \propto J_\theta$. Note, however, that the spin S varies as $\cos\theta$. As is well known, there

is a correlation here with the polarization of the far electric fields. For emission in the $\pm z$ direction where $\cos\theta = \pm 1$, it may be shown that \mathbf{E}^{far} rotates in the xy plane (see Eq. [9] and problem 9, Appendix B.1.). In other words, the radio waves are circularly polarised. However, for transverse radiation where $\cos\theta = 0$, this is not the case, and the radio waves are linearly polarized with their electric field in the z direction. We may therefore associate circular polarisation, depending on its helicity, with a spin eigenvalue of ± 1 , and linear polarization with a net spin of 0 comprising $+1$ and -1 spin photons. At an arbitrary declination θ , the radio waves are elliptically polarized and we must assume that they comprise photons having admixtures of spin eigenvalues. (Photons do not have an eigenvalue of zero.)

The Near Rotational Momentum

We have thoroughly explored radio waves and their connection to quantum concepts. Furthermore, we have seen that their linear momentum, as derived from $\mathbf{D} \times \mathbf{B}$, can be interpreted as either being an expression of energy when radial via $U = pc$ or of angular momentum gradient when azimuthal via $\mathbf{p} = 4/3 \text{ curl} \mathbf{J}/2$. However, what are we to make of the near azimuthal momentum

$$p_\phi^{\text{near}} = \frac{m^2 \mu_0 \omega \sin\theta}{16\pi^2 c^2 r^5} \quad [31]$$

with its connection to the near electric field, near stored energy, and the NMR signal? Clearly it cannot be interpreted as a flow of energy $p_\phi^{\text{near}} c$, for there is no term in \tilde{U} (Eq. [T5]) with linear frequency dependence. As there is no evidence of any other directed energy flow nor may we easily interpret it as the curl of some angular momentum distribution. (The reader may wish to try.) However, if we multiply by $r \sin\theta$ to obtain an angular momentum density, we have

$$\tilde{\mathbf{j}}^{\text{near}} = \frac{m^2 \mu_0 \omega \sin^2\theta}{16\pi^2 c^2 r^4} \hat{\mathbf{z}} \quad [32]$$

This is precisely the near field energy component in Eq. [T5] divided by the angular frequency ω . In other words, we have the normal relationship $U = J\omega$ for photons (rather than $U = 1/2 J\omega$ for a solid) and further, there is a common declinational dependence—both are proportional to $\sin^2\theta$. We apparently have photons, but they are going nowhere, something that once again emphasises the very different natures of near and far fields.

Taking a different approach, the common $\sin^2\theta$ dependence of \mathbf{J}_{near} and \tilde{U}^{near} is reminiscent of the angular momentum of a spinning ball which, of course, has kinetic energy. If the mass density of the ball is $\sigma(r)$ then the angular momentum of an elementary volume dV at point $P[r, \theta, \phi]$ rotating about the z axis is

$$dJ_{\text{ball}} = \omega dI = \sigma r^2 \sin^2\theta \omega dV; \quad dI = \sigma dV \rho^2 \quad [33]$$

where dI is an elementary moment of inertia. By comparing Eqs. [32] and [33], we have that an equivalent mass density is

$$\sigma \equiv \frac{m^2 \mu_0}{16\pi^2 c^2 r^6} \quad [34]$$

The total “magnetodynamic mass” is then

$$M = \int_{r=r_0}^{\infty} \int_{\theta=0}^{\pi} \sigma 2\pi r^2 \sin\theta \, dr d\theta = \frac{m^2 \mu_0}{12\pi c^2 r_0^3} \quad [35]$$

where r_0 is some lower limit of radius. [Letting $r_0 \rightarrow 0$ opens a Pandora’s Box of infinities, c.f. Feynman (9, Ch. 28).] Interestingly, if we now integrate with the same limits the static magnetic field energy density in Eq. [T4] (problem 10, Appendix B.1.) to find its total energy, we obtain exactly Mc^2 . The implication is that the near field energy—which, in turn, is associated with the near electrodynamic field and hence Faraday induction—is also associated with the kinetic energy of precession of the protons; the latter may be written in the form $1/2 I\omega^2$, I being moment of inertia. However, as with the far rotational momentum calculation, there is no declinational correspondence between “mass” and angular momentum, and no simple trickery involving a factor of 4/3 has been found to concoct one. The general concept of electromagnetic mass is an old one and its discovery initially caused considerable excitement as it was thought that it explained the origins of all mass. It was in the relationship between electrostatic mass (from Coulomb’s Law) and the mass associated with the magnetic field of a moving charge that the factor of 4/3 was first revealed, as described by Moylan (39).

In passing, it may occur to the reader that the precessional kinetic energy $U = 1/2 I\omega^2$ and the near field energy with their squared frequency dependences are at odds with the well-known expression $U = \mathbf{m} \cdot \mathbf{B}_0$. However, it must be remembered that the torque imposed by the B_0 field is a small perturbation on the nuclear spin and its energy, and at least in

classical terms Goldstein (40) shows that there is no conflict between the two expressions of energy.

VIRTUAL PHOTONS

An Exercise in Relativity

It is highly desirable to have an integrated quantum description of all aspects of NMR, of which signal reception is an important component. The author is very conscious of the fact that along with claiming that part of that description is wrong goes the responsibility of providing a better explanation—one that must perforce encompass the near-field energy and the (to the author) frustrating insights into the energy-momentum relationship that we have just explored. Unfortunately, however, the quantum physics of near-field phenomena is incomplete and obdurate. A start was made in the articles published in 1997 and 2001 (2, 6) in which virtual photons were introduced to a sceptical NMR community. We are at the troubled interface of relativity and quantum mechanics, for let us not forget where this article began: Einstein’s Principle of Special Relativity and Coulomb’s Law for the force between electrically charged objects. We did not then attempt to push our starting points further back and inquire as to the origins of the electrostatic interaction. However, we must now do so for there are considerable similarities with the problem of trying to explain Faraday’s Law of induction; indeed, the problems are linked by Maxwell’s equations. In the case of Coulomb’s Law, the force is linear, being directed along the line joining the charges and attempting to change their separation; for Faraday’s Law, the force is a torque attempting to move charges round a circular path.

The discipline offering the best chance of an explanation is quantum electrodynamics (QED) but an extensive literature search reveals no publication dealing with the quantum nature of Faraday’s Law, probably because QED is mainly applied to high-energy physics and lies in the abstract domain of field theorists. (A relatively accessible book on QED is that by Cohen-Tannoudji et al. (41)). Thus the reader will find unsatisfactory the following attempt to give insight into the mixing of the Uncertainty Principle and relativity, for the author is no field theorist. However, if nothing else, it may perhaps stimulate others to do a better job!

First, let us deal with a misconception. The perception has filtered into mainstream science from QED that photons are responsible for the forces between two charges. However, this idea (at least

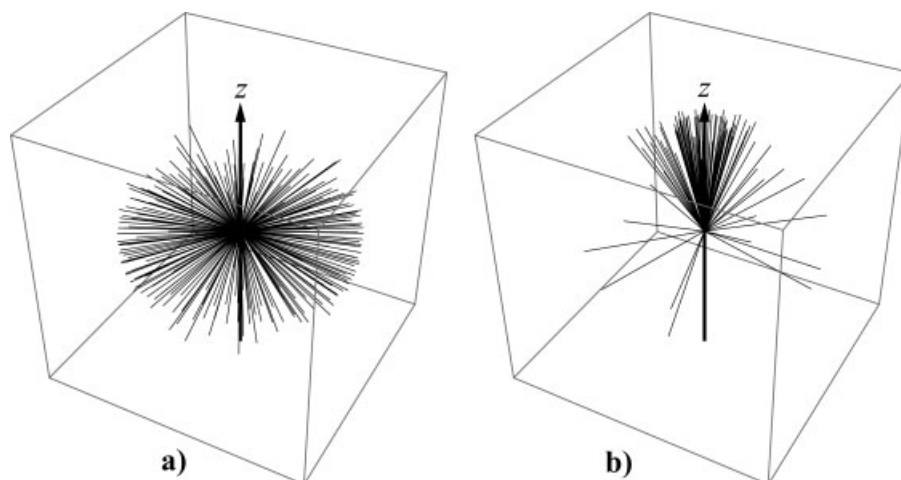

Figure 4 Two relativistic distribution functions drawn directly from their mathematical expressions. (a) Representation of the lines of electrostatic force surrounding a charged particle moving at relativistic speed ($0.98c$) in the z direction. The lines congregate in the transverse plane. (b) Shows how photons, emitted isotropically from an object in the rest frame, congregate about the z direction when the object is moving at the same relativistic speed in that direction. It follows that emission of photons cannot explain the electrostatic force.

with a conventional understanding of photons as particles/waves carrying energy) does not in most cases bear close scrutiny: If a proton is alone in space, is it shooting off in all directions photons bearing the electromagnetic field? If so where does the energy come from and what is the photons' frequency ω ? How is electrostatic attraction explained? etc. Using a "pop. physics" picture, we may envision two astronauts floating in space throwing tennis balls to each other, and thereby effectively experiencing a repulsive force via an exchange of "particles," but this requires positional knowledge if tennis balls are not to be lost in space. Furthermore, if we try and use the same method to model an attractive force, we are confounded. Are we to propose tennis balls with negative mass and momentum? How about tennis balls moving backwards in time? It is a truism to say that our attempts at understanding such things are preconditioned by our experience and we therefore rebel at such nonsensical ideas. Yet such concepts can and are entertained in QED and the Uncertainty Principle is one of the foundations of the subject that allows us to do so.

Feynman spent much time thinking about these things and his aptly titled popular exposition "QED—The Strange Theory of Light and Matter" (42) is well-worth reading. In it he states (p 10), "The theory of quantum electrodynamics describes Nature as absurd from the point of view of common sense. And it agrees fully with experiment."

There is, however, a simple and instructive relativistic exercise that can give direction, and the author can thoroughly recommend the book "Spacetime Physics" by Taylor and Wheeler (13) as a highly readable introduction to special relativity. Considering Coulomb's Law, our exercise involves a simple question: what happens to the electric field of a charged particle when it moves at a speed v approaching that of light c ? Purcell (the same) in his excellent text on electromagnetism (12, Ch. 5) gives the answer. He shows that the field lines tend to bunch in the plane perpendicular to the direction of motion z with a distribution function $H(\theta)$ given by

$$H(\theta) = \left(1 - \frac{v^2}{c^2}\right) \left(1 - \frac{v^2}{c^2} \sin^2\theta\right)^{-3/2} \quad [36]$$

as shown in Fig. 4(a). As $v \rightarrow c$ so $H(\theta) \rightarrow \infty$ as $\theta \rightarrow 90^\circ$.

Consider the particle, stationary in its own frame of reference (r' , θ' , ϕ') denoted by primes, somehow emitting photons isotropically despite our earlier strictures. The photons carry energy U' and momentum p' and we are interested in the number per second emitted between declinational angles $\theta' - d\theta'/2$ and $\theta' + d\theta'/2$. Looking at the surface area of the unit sphere between these limits, for isotropic emission that number is proportional to $\sin\theta' d\theta'$. Now in going from the charge's (primed) frame to the laboratory (unprimed) frame, Taylor and Wheeler show

that the relativistic transformation equations for energy and momentum are (13, p 114)

$$\begin{aligned} U' &= -pc \cos\theta \sinh\zeta + U \cosh\zeta \\ p' \cos\theta' &= p \cos\theta \cosh\zeta - U/c \sinh\zeta \\ p' \sin\theta' &= p \sin\theta \end{aligned} \quad [37]$$

where $\tanh \zeta = v/c$. For a photon, $U = pc$ and $U' = p'c$, and so solving for $\cos\theta$, we obtain

$$\cos\theta = \frac{v + c \cos\theta'}{c + v \cos\theta'} \quad [38]$$

However, as velocity $v \rightarrow c$, $\cos\theta \rightarrow 1$ and so $\theta \rightarrow 0$ regardless of the value of θ' . In other words, at high speed the photons emitted isotropically in the rest frame are concentrated in the forward direction in the laboratory frame as shown in Fig. 4(b), a phenomenon Taylor and Wheeler refer to as the “headlight effect” (13, p 69). This is clearly in direct opposition to the distribution function of Eq. [36] and, confirming our earlier ideas, proof that the electrostatic interaction cannot be mediated by photons. A further indication is the fact (not as well known as it should be) that a charged particle cannot permanently absorb or emit a photon while conserving relativistic energy and momentum (see problem 11, Appendix B.1.).

We are not, however, quite finished with photons. Let us use Eqs. [37] in an absurd fashion and, violating the relation $U = pc$, set the energy U in the laboratory frame to zero while leaving the momentum p alone. (Note that if the charge is moving U' is not zero and further can be negative.) From the second and third equations we immediately obtain

$$\tan\theta = \tan\theta' \cosh\zeta \quad [39]$$

Finding the expression for $\cos\theta'$ in terms of θ and differentiating leads to

$$\begin{aligned} \sin\theta' d\theta' &= \left(1 - \frac{v^2}{c^2}\right) \left(1 - \frac{v^2}{c^2} \sin^2\theta\right)^{-3/2} \sin\theta d\theta \\ &\equiv H(\theta) \sin\theta d\theta \end{aligned} \quad [40]$$

In other words, the number of photons emitted between angles $\theta - d\theta/2$ and $\theta + d\theta/2$ is modulated by the distribution function $H(\theta)$ given by Purcell for the relativistic electrostatic field. Apparently, photons with zero energy but normal momentum emitted isotropically in the rest frame have the same spatial distribution in the moving frame as an electrostatic field. Is this coincidence?

Fortunately, setting the energy U to zero while maintaining p is not quite as absurd as it seems, provided we do it transiently. One of the statements of Heisenberg’s Uncertainty Principle (8, 43) is that $\Delta U \Delta t \sim \hbar$ and applying this, we have that if the deviation in U from its normal value of $\hbar\omega$ is $\Delta U = |-\hbar\omega|$ giving $U = 0$, then the time this excursion is allowable is $\Delta t \sim 1/\omega$. A photon with the “wrong” energy for a short time is known as a “virtual photon” and if we can accept this assault on common sense, then apparently, the electrostatic interaction may be due to an exchange of such virtual photons—our astronauts’ tennis balls are virtual and may be flung in all directions, fading away in a time $\sim \Delta t$ as they do so. Note too that once the Uncertainty Principle has been invoked, negative energy, momentum and time are all possible. Now given that our virtual photon still travels at the speed of light, it can cover in a time Δt a distance of the order of a reduced wavelength $r = c/\omega = \lambda$. Examination of Eq. [T1] shows that this is precisely the distance beyond which the far electric field (coherent real photons) takes over as the dominant force. This is intriguing as we now have two pieces of evidence that suggest that virtual photons may be considered to account for near electric fields, the electrostatic field being the ultimate “near” field. Note that just as the far field photons in a radio wave are coherent, the near field virtual photons from a rotating magnetic moment must be also.

It might be argued that the author is “mixing apples and oranges” by considering the electrostatic interaction while employing a virtual photon associated with a transverse oscillating electric field. One devious retort would be that as the universe does not possess infinite age, there is no such thing as a “static” field and that it is simply an alternative representation of the linear momentum of vast numbers of incoherent virtual photons having frequencies in the fHz range and less. A more conventional QED answer would be that in general, a virtual photon has four polarisation states: x, y, z and time (42, p 120). It is stressed that virtual photons are not an invention of the author and they are mentioned by Jackson (10, p 3) in relation to \mathbf{E} and \mathbf{B} . They are an integral and contentious part of quantum electrodynamics. The reader is urged to read “The New Physics” edited by Davies (44) for a popular explanation and descriptions are also beginning to appear on the Web. For example, there is a Wikipedia site on virtual particles (45) that ascribes the near field of antennas to virtual photons. The concept is becoming well known and (perhaps reluctantly) accepted as an explanation for near-field phenomena. The reluctance stems from the

awkwardness of the model, which to use Feynman's term is "strange," and the impracticality of the associated QED mathematics—embarrassing infinities tend to pop up in the manner of Eq. [35] with $r_0 \rightarrow 0$.

Photon Localization

To conclude, we engage in unsubstantiated speculation concerning the near angular momentum and energy. The relationship $U = J\omega$ between energy and angular momentum is indicative of real photons; the absence of linear radial momentum implies the absence of real photons which led the author to the concept of "magnetostatic mass" as a way out of the paradox. Another solution to the paradox may lie in the realisation that just as electrons can be localized (e.g., in an atom) real photons also can be localized (46). Such localized energetic entities with zero radial momentum may be considered to have localized mass. In analogy to electrons, consider N pairs of these photons around a proton at radius $\lambda/2\pi$ so that the path is one wavelength. (Photons are bosons so there is no restriction on the number of particles in the same "energy level.") If the linear azimuthal momentum of half the photons counters that of the other half, the net linear azimuthal energy flow is zero, as is the net spin. However, as the photons can carry orbital angular momentum perpendicular to the direction of propagation, and in particular in the z direction, this may account for J_z . The manner in which this utterly speculative approach meshes with the concept of zero-energy virtual photons is unclear, but they could be complementary, with one entity providing the energy and the other the momentum.

Discussion

In admitting the concept of virtual photons, the author would urge the reader to move beyond the idea that the interactions associated with them are due to an exchange of particles akin to astronauts swapping tennis balls. It is sometimes said that photons (real or virtual) are either wavelike or particle-like; it is perhaps better to realize that photons are simultaneously both, and manifest different aspects according as the experimenter's demands—the role of the observer again. For example, the tennis ball thrown by one astronaut may need already to be at the other! To quote Feynman again (42, p 82) "The more you see how strangely Nature behaves, the harder it is to make a model that explains how even the simplest phenomena actually work." There are two insights that have helped the author in this regard. The first is the Uncertainty relationship

$\Delta U \Delta t \sim \hbar$ that we have already explored; the second is the related Uncertainty relationship $\Delta p \Delta r \sim \hbar$. If we define a virtual photon as a particle with a definite momentum, there is no uncertainty ($\Delta p = 0$) in that momentum but correspondingly we have no idea where the particle is ($\Delta r \sim \infty$). It could be both at the precessing nuclear magnetic moment and at an electron in a receiving loop. This idea of nonlocalization is consonant with current ideas of mass. For example, an electron can be a point object, as is found in some nuclear physics experiments or it can be a fuzzy energy cloud surrounding a nucleus with some of its mass given by the stored electrostatic energy divided by c^2 (Einstein's $U = mc^2$). The point here is that for photons, electrons and protons, all three are particles and all three are smeared out and are waves, simultaneously. (The electromagnetic mass comprises only a small part of the proton mass. For an electron, however, it comprises a substantial portion.)

Finally, we must acknowledge the fact that observation of the NMR signal demands energy from the nuclear system. That energy either (pick your explanation) 1) passes through space, via the administrations of virtual photons, from the protons to the electrons in the receiving coil and thence to the first transistor in the preamplifier or 2) in an interactive dance is extracted by the electrons from the encompassing electromagnetic fields/localized photons that are part of the precessing proton or 3) both the former simultaneously. Is the energy quantised? Going out on a limb, the author would argue that provided we do not attempt to measure individual quanta, each virtual photon can carry an arbitrary energy, the sum tending to the classical limit calculated from Faraday's Law and the impedance of the radio frequency circuit. The extraction of energy is accompanied by longitudinal relaxation (so-called "radiation" damping) as energy $\mathbf{m} \cdot \mathbf{B}_0$ decreases, but it is stressed yet again, as described in Appendix A.2., that the amount of energy used in optimal detection depends completely on the skill of the electrical engineer who designs the preamplifier and its interface to the receiving coil. As has been mentioned, a supposed link between signal-to-noise ratio and "radiation" damping was an integral part of the early publications on the quantum origins of the NMR signal (5), but Hault and Ginsberg (6) gives graphic experimental evidence of a lack of linkage between the two. This too is briefly discussed in Appendix A.2. Finally, it should be clear by now that the appellation "radiation damping" for this relaxation phenomenon is a misnomer; a better term might be "inductive damping."

CONCLUSION

We have examined several facets of a single variable—the retarded vector potential [A]—and from that examination presented strong evidence, confirmed by experiment, that coherent spontaneous emission (radio waves) is not responsible for the vast majority of the NMR signal induced in an open-circuit receiving coil. Rather, most NMR is a near-field phenomenon described accurately and classically by Faraday’s Law. Given that the latter is derived from Coulomb’s Law with the aid of relativity, it seems reasonable to accept the QED concept that coherent virtual photons provide the near electric field that gives an electromotive force and to associate them with near angular momentum. Then, if we insist on trying to have a quantum explanation for the NMR signal, virtual photons may provide a reasonable foundation, though how a workable and realistic Hamiltonian that meshes with the rest of NMR may be created is unclear. The reader should note that we have not proved in any way that virtual photons are responsible for the FID or indeed for Faraday induction. Such proof would be a major exercise in QED and the author knows of no directly relevant research article. Rather, the author has merely tried to give insights that are consonant with modern physics to the best of his limited knowledge.

ACKNOWLEDGMENTS

The author acknowledges discussions with Dr. J. Hovdebo and thanks Dr. H. Eviatar for critically reading the manuscript. The first referee is thanked for confirmation of the author’s apparently “iconoclastic” approach, for insightful comments that have hopefully improved the logical and philosophical foundations of the article and for the suggestion of reference (19). The second referee is thanked for comments that caused the author to clarify what is meant by NMR signal reception and to give a definition that hopefully removes ambiguity.

APPENDIX A

A.1. Of Distributed Angular and Linear Momenta

Consider an ensemble of spinning objects distributed through space \mathbb{R}^3 with vector object density $\tilde{\mathbf{N}}(\mathbf{r})$. Let each object possess angular momentum in the form of a distribution of linear momentum p cir-

culating about a central axis whose direction is that of $\tilde{\mathbf{N}}$, as shown in Fig. A1. In the frame local to an object, at position (r'', θ'', ϕ'') let its linear momentum density be $\tilde{p}_{\phi''}(r'', \theta'')$, a function that is symmetric about the transverse $x''y''$ plane that passes through $\tilde{\mathbf{N}}$. Then in a volume dV of \mathbb{R}^3 containing many such objects, the angular momentum density is

$$\tilde{\mathbf{J}} \simeq \left\{ \int_{r=0}^{\infty} \int_{\theta=0}^{\pi} \tilde{p}_{\phi''}(r'', \theta'') 2\pi r''^3 \sin^2\theta'' dr'' d\theta'' \right\} \tilde{\mathbf{N}}(\mathbf{r}) \tag{A1}$$

where it is assumed that $\tilde{p}_{\phi''}$ is independent of $\tilde{\mathbf{N}}$ and also that the integral is convergent; i.e., $\tilde{p}_{\phi''}$ falls off rapidly with radial distance r'' .

Now consider the linear momentum density at some local origin O. In general, objects in elementary volume dV at position \mathbf{r}' relative to O contribute

$$d\tilde{\mathbf{p}} = \tilde{p}_{\phi''}(r'', \theta'') \frac{\mathbf{r}' \times \tilde{\mathbf{N}}}{r' \sin\theta'} dV \tag{A2}$$

where $r'' = r'$ and θ'' is now a function of r' and the direction of $\tilde{\mathbf{N}}$. We may integrate over all space to find the total linear momentum, but by symmetry, if $\tilde{\mathbf{N}}$ is homogeneous, the result will be zero. If, however, $\tilde{\mathbf{N}}$ is a slowly varying function of spatial posi-

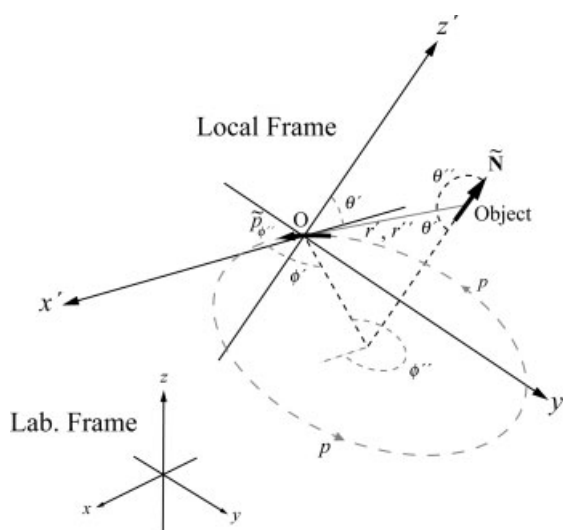

Figure A1 The orientations and positions of an object and a local frame relative to the laboratory frame. A third frame (not shown for clarity), denoted by two primes, is centered on the object, which carries angular momentum (in direction z'') associated with circulating linear momentum p .

tion, the metric of distance being the spatial extent of the function \tilde{p}_ϕ , then in the region of space about O, we may expand \tilde{p}_ϕ and $\tilde{\mathbf{N}}$ by Taylor's theorem to obtain an approximate result. Unfortunately, the resulting expression becomes cumbersome even when only expanding to first order. We therefore make the further assumption that to high accuracy all central axes in the local region are in alignment. Without loss of generality, we may then for convenience let the common direction of $\tilde{\mathbf{N}}$ about O be z' , as shown in the figure. We now have, in addition to $r'' = r'$, that $\theta'' = \pi - \theta'$ and $\phi'' = \pi + \phi'$, and so the Cartesian linear momentum density at the origin may be seen to be

$$\tilde{\mathbf{p}} \approx \int_{\text{all space}} \tilde{p}_\phi(r', \theta') [\sin\phi', -\cos\phi', 0] \times \left\{ N_{z0} + \frac{\partial N_{z'}}{\partial x'} x' + \frac{\partial N_{z'}}{\partial y'} y' + \frac{\partial N_{z'}}{\partial z'} z' + \dots \right\} dV \quad [A3]$$

Writing x' , y' , and z' in their spherically polar forms, integrating in ϕ' , and comparing with Eq. [A1],

$$\tilde{\mathbf{p}} \approx \int_{r=0}^{\infty} \int_{\theta=0}^{\pi} \tilde{p}_\phi(r', \theta') \pi r'^3 \sin^2\theta' dr' d\theta' \left[\frac{\partial N_{z'}}{\partial y'}, -\frac{\partial N_{z'}}{\partial x'}, 0 \right] = \frac{1}{2} \left[\frac{\partial \tilde{J}_{z'}}{\partial y'}, -\frac{\partial \tilde{J}_{z'}}{\partial x'}, 0 \right] \quad [A4]$$

where we have assumed that the derivatives of $\tilde{\mathbf{N}}$ are essentially constant over the extent of \tilde{p}_ϕ . Reverting from the local frame to the principal laboratory space \mathbb{R}^3 whose z axis will not in general be coincident with z' , we then have that

$$\tilde{\mathbf{p}} = \frac{1}{2} \text{curl} \tilde{\mathbf{J}} \quad [A5]$$

Whether such a derivation, based essentially on mechanical arguments, may be applied to an ensemble of photons is a moot point.

A2. Energy Absorption During Signal Reception

The purpose of this Appendix is to show that the amount of power absorbed from the NMR system during signal reception with optimal signal-to-noise ratio (S/N) is arbitrary and, within broad limits, under the control of the design engineer. It follows that there is no unique and simple linkage between "radiation" damping and S/N.

i. Transistor Characteristics and Optimal Source Impedance. Any examination of the absorption of energy during signal reception must begin with a reputable electrical model of the first transistor in the preamplifier. Various models are available, but that of Fig. A2(a) is simple yet reasonably accurate at radio frequencies (47). Its main defect is that it ignores C_{bc} , the base-collector capacitance. In the figure, a signal source of impedance Z_s is connected to the base of a bipolar transistor operating in common-emitter mode. The signal itself is a voltage V_s whereas the Johnson noise associated with the real part R_s of the source impedance is random white noise of r.m.s. voltage

$$N_s = \sqrt{4kT_s R_s \Delta f} \equiv \beta \sqrt{R_s} \quad [A6]$$

Here k is Boltzmann's constant, T_s is the source temperature, and Δf is the bandwidth of the measuring device. Of key importance is the relationship of R_s not only with noise N_s but also with the signal voltage V_s . We assume that the source includes a lossless impedance transformation of some sort, and in such a transformation, by conservation of energy, V_s^2/R_s must be a constant. Thus let

$$V_s = \xi_0 \sqrt{R_s} \quad [A7]$$

where ξ_0 is a normalized constant e.m.f. Note that the source signal-to-noise ratio V_s/N_s remains constant under the lossless impedance transformation.

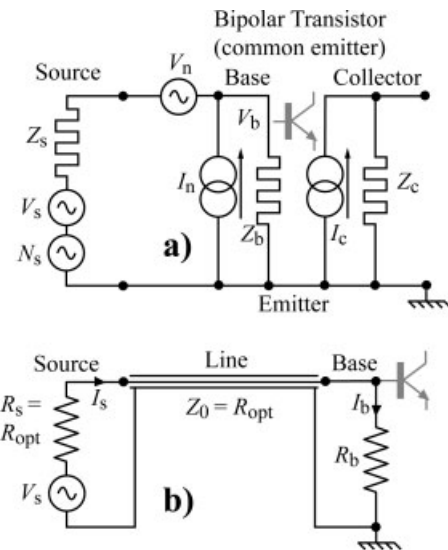

Figure A2 Idealized circuits for analyzing power absorption during amplification with minimal addition of noise.

Resistance R_s will be the primary variable in the ensuing calculation. The reactive portion X_s of the source impedance varies in a manner that is dependent on the details of the transformation and at any particular frequency can always be forced to a particular value by the addition of capacitance or inductance. We shall therefore simply write that $Z_s = R_s + iX_s$ where $i = \sqrt{-1}$.

The transistor has a base input impedance Z_b which for the purposes of modeling is considered noiseless. The noise is represented instead by a noise voltage source V_n and a constant noise current source I_n , and in practice these sources may be lightly correlated. Across impedance Z_b is the base voltage V_b due to the source and the noise. The collector output of the transistor is represented by a constant current source $I_c = g_m V_b$ in parallel with an impedance Z_c and the amplified signal is passed on from this point to the receiver chain. Here, g_m is transconductance. We shall not consider I_c further, relying instead on the proportionate base voltage V_b as a measure of signal and noise.

Having set the scene, our goal now is to maximize the signal-to-noise ratio (S/N) of the collector current (base voltage) by optimization of source resistance R_s . We begin by considering the signal that is passed to the transistor base. By potential division, it is

$$S_b = V_s \frac{Z_b}{Z_b + Z_s} = \xi_0 \sqrt{R_s} \frac{Z_b}{Z_b + R_s + iX_s} \quad [\text{A8}]$$

Now consider the noise at the transistor base. This is more difficult to calculate. Consider first the voltage N_{b1} created by the transistor constant current noise source applied to Z_s and Z_b in parallel. It is

$$N_{b1} = I_n \frac{Z_b(R_s + iX_s)}{Z_b + R_s + iX_s} \quad [\text{A9}]$$

Now consider the voltage N_{b2} created by the transistor voltage noise V_n . It is

$$N_{b2} = V_n \frac{Z_b}{Z_b + R_s + iX_s} \quad [\text{A10}]$$

If N_{b1} and N_{b2} were totally correlated, they would add linearly, albeit with differing phases; if they were uncorrelated they would add quadratically. Thus for partial correlation we may write for their combined voltages

$$N_{b12}^2 = |N_{b1}|^2 + |N_{b2}|^2 + 2\gamma |N_{b1}| |N_{b2}| \quad [\text{A11}]$$

where γ is a correlation factor, ranging from 0 (no correlation) to 1 (full correlation), that is dependent both on the noise correlation and the phase difference. The source noise N_s is uncorrelated with the transistor noise and therefore adds quadratically to the noise in Eq. [A11]. Summing, the mean square noise at the base is

$$N_b^2 = \left(\frac{Z_b Z_b^*}{|Z_b + R_s + iX_s|^2} \right) (\beta^2 R_s + I_n^2 (R_s^2 + X_s^2) + V_n^2 + 2\gamma V_n I_n \sqrt{R_s^2 + X_s^2}) \quad [\text{A12}]$$

Hence, from Eq. [A8], the square of the signal-to-noise ratio Ψ at the transistor base is given by

$$\begin{aligned} \Psi^2 &= \left(\frac{S_b}{N_b} \right)^2 \\ &= \frac{\xi_0^2 R_s}{\beta^2 R_s + I_n^2 (R_s^2 + X_s^2) + V_n^2 + 2\gamma V_n I_n \sqrt{R_s^2 + X_s^2}} \end{aligned} \quad [\text{A13}]$$

Note that the base input impedance of the transistor has dropped out of the equation. When there is no correlation ($\gamma = 0$), Ψ^2 is easily maximized by differentiation w.r.t. R_s and X_s and we obtain the well-known result $R_s = R_{\text{opt}} = V_n/I_n$ and $X_s = 0$. It may then be shown that correlation merely reduces the signal-to-noise ratio and has little effect on the optimal values. For use below, we note that for a perfect amplifier $\Psi = \Psi_{\text{max}} = \xi_0/\beta$ in the current notation.

ii. Power. In the NMR frequency range, R_{opt} for a bipolar transistor in the common emitter configuration is typically 50 to 200 Ω whereas the input impedance Z_b is typically 500 to 2,000 Ω and predominantly resistive. MOSFETs are sometimes used in preamplifiers and for these, R_{opt} is typically 500 to 2,000 Ω whereas the input impedance is predominantly capacitive in parallel with tens of kilohms. However, many MOSFETs do not perform well in strong magnetic fields and have orientation-dependent characteristics, so we remain with bipolar transistors.

Conceptually, the simplest of connections between a source and a transistor is that shown in Fig. A2(b): a coaxial cable of characteristic impedance $Z_0 = R_{\text{opt}}$ makes the link while the source impedance has been transformed to R_{opt} . Then, $V_s = \xi_0 \sqrt{R_{\text{opt}}}$. Neglecting cable loss, from the perspective of the transistor the only thing that changes as the length of the cable is varied is the phase of the

signal. The magnitude of the current entering the transistor's base is always

$$|I_b| = \frac{V_s}{R_s + R_b} \quad [\text{A14}]$$

and the power deposited in the base is

$$W_b = \left(\frac{V_s}{R_s + R_b} \right)^2 R_b \quad [\text{A15}]$$

However, this is not the total power spent, as some is also deposited in the source resistance R_s . It might then be thought that the total power is $V_s^2 / (R_s + R_b)$, but this formulation takes no account of power reflected back down the line by the unmatched termination R_b . To access the total power, we must know the impedance (as transformed by the line of length l) presented by the transistor to the source. It may be shown to be

$$Z'_b = Z_0 \frac{-Z_0 + e^{4i\pi l/\lambda}(Z_0 + R_b) + R_b}{Z_0 + e^{4i\pi l/\lambda}(Z_0 + R_b) - R_b} \quad [\text{A16}]$$

where λ is wavelength in the line. Of particular interests are the extrema of the magnitude of this quantity. These occur when $\sin[4\pi l/\lambda] = 0$. When $l = 0$, the result is, of course, $Z'_b = R_b$, but when $l = \lambda/4$ the result is $Z'_b = Z_0^2/R_b = R_{\text{opt}}^2/R_b$, a radically different value. The resulting powers absorbed from the source are also very different. For no cable,

$$W_0 = \frac{V_s^2}{R_{\text{opt}} + R_b} \simeq \frac{V_s^2}{R_b} \Big|_{R_b \gg R_{\text{opt}}} \quad [\text{A17}]$$

whereas for a $\lambda/4$ cable, the power absorbed is much greater, being

$$\begin{aligned} W_{\lambda/4} &= \frac{V_s^2}{R_{\text{opt}} + R_{\text{opt}}^2/R_b} \simeq \frac{V_s^2}{R_{\text{opt}}} \Big|_{R_b \gg R_{\text{opt}}} = \xi_0^2 \\ &= \beta^2 \Psi_{\text{max}}^2 \end{aligned} \quad [\text{A18}]$$

The ratio of the two powers is

$$\frac{W_{\lambda/4}}{W_0} = \frac{1 + R_b/R_{\text{opt}}}{1 + R_{\text{opt}}/R_b} \simeq \frac{R_b}{R_{\text{opt}}} \Big|_{R_b \gg R_{\text{opt}}} \quad [\text{A19}]$$

It is left to the reader to show that in the $\lambda/4$ case, the power absorbed by the transformed transistor base impedance $Z'_b = Z_0^2/R_b = R_{\text{opt}}^2/R_b$ is the same as that in Eq. [A15].

To a considerable extent, the total power absorbed from the source is clearly under the con-

trol of the circuit designer: one chooses a transistor with a large ratio of effective parallel input resistance R_b to optimal source resistance R_{opt} and then manipulates cable length to minimise the absorption. The simplest possible scenario was used above to demonstrate the phenomenon; nevertheless it is generally applicable and has been known in NMR for many years (32–34). Its most common application is in imaging, where it is used for current blocking of an array of coils during signal reception (34), but its highly efficient use to suppress “radiation” damping is illustrated experimentally by Hoult and Ginsberg (6; Fig. 8). They show that the special limiting case of maximum power absorption in Eq. [A18] (5), in which the source resistance is predominant, is equivalent to that encountered when considering just an LC tuned circuit as the detector. There, the losses in the receiving coil predominate and conveniently and very misleadingly, there is a relationship between power absorption (i.e. “radiation” damping) and signal-to-noise ratio that is demonstrated in Eq. [A18] (5). However, it should now be clear that this elegant relationship is neither pivotal nor fundamentally important and that it springs, in fact, from the worst scenario that could possibly have been chosen from the point of view of “radiation” damping. (It also illustrates the danger of the mindset that says “This is so elegant it has to be right.”) Essentially, the link between signal-to-noise ratio and “radiation” damping is weak and under the control of the circuit designer.

APPENDIX B

B.1. Problems

The following problems elucidate certain points in the text, and in accord with the Journal's pedagogical approach, aid self-testing:

1. Show from Eqs. [2] and [3] that the magnetic field at the origin due to a unit current element at point S in the receiving loop of Fig. 1 is $d\hat{B}_x = \frac{\mu_0 d\psi}{4\pi a} \left(1 + \frac{ib\omega}{c}\right) e^{i\omega(t-\frac{b}{c})}$, where $d\psi$ is the angular width of the element and b is the radius of the receiving loop. From Eq. [6] now show that the elementary voltage induced in an element at point S by an oscillating dipole m_x at the origin is $d\xi = -i\omega m_x d\hat{B}_x$. This is an example of the Principle of Reciprocity.
2. In problem 1, consider that the circular receiving loop sits above a ground plane (e.g. the sample) and is essentially a transmission

- line down which the electrical disturbance $d\xi$ travels at a little less than the speed of light. If point S in Fig. 1 is at declination ψ , show that neglecting losses, the voltage across the gap is given by $d\xi' = d\xi \cos\left(\frac{2\pi b\psi}{\lambda'}\right) \sec\left(\frac{2\pi^2 b}{\lambda'}\right)$, where λ' is the wavelength on the line. Now remove the voltage $d\xi$ and with a current source inject unit current into the line at the loop gap. Show that the current at point S is the expression just derived with $d\xi = 1$. This relationship extends the Principle of Reciprocity of problem 1 to the case where the receiving coil is not small in comparison with wavelength. (The result may be further extended to include losses by making λ' complex).
- Derive Eq. [T2] from Eq. [10] using the definition of retarded magnetic moment found in Eq. [7].
 - Using Eqs. [9] and [16] for the far electric and magnetic fields, show that they are orthogonal to one another and that the cross product $\epsilon_0 \mathbf{E} \times \mathbf{B}$ is the term p_r of Eq. [T6].
 - A square loop antenna with a small gap and of side $s \ll \lambda$ has the normal to its plane parallel to the magnetic field of a radio wave. Show that the magnitude of the voltage V_E across the gap created by the radio wave's electric field \mathbf{E} is $2\pi E s^2/\lambda$. Now calculate the voltage V_B induced in the loop by the magnetic field \mathbf{B} . Explain why V_B and V_E are equal. Is the voltage across the gap one of these quantities or the sum of them?
 - The near momentum circulating round a rotating magnet is given by the term in ω of p_ϕ in Eq. [T6]. Calculate the associated angular momentum in a shell of thickness dr and show that it agrees with Eq. [19].
 - The static magnetic field of a magnetic moment \mathbf{m} is given by $\mathbf{B} = \frac{\mu_0}{4\pi} \left[\frac{3\mathbf{r}(\mathbf{r}\cdot\mathbf{m})}{r^5} - \frac{\mathbf{m}}{r^3} \right]$ and the energy per unit volume stored in the field is $\tilde{U} = \mathbf{B}\cdot\mathbf{B}/(2\mu_0)$. Calculate \tilde{U} and reconcile your result with the first term in Eq. [T5].
 - From Eq. [32] and working in cylindrical polar coordinates $[\rho, \phi, z]$, the angular momentum J_z in the z direction associated with the photons emitted by a rotating magnet is $J_z = C(2z^2 + \rho^2)(z^2 + \rho^2)^{-2}$, where C is a constant. From the final term in Eq. [T6] the far azimuthal linear momentum flux is $p_\phi^{\text{far}} = 2C\rho/(z^2 + \rho^2)^2$. If the total momentum $\mathbf{J} = [J_\rho(\rho, z), 0, J_z]$ and $A \text{ curl } \mathbf{J} = [0, p_\phi^{\text{far}}, 0]$, show that J_ρ is only finite for all z and ρ if $A = 2/3$.
 - From Eq. [T1], show that the alternating electric field may be resolved into components

E^+ and E^- that have, respectively, positive and negative rotations about the \mathbf{r} direction, where $E^+ \propto 1 - \cos\theta$ and $E^- \propto 1 + \cos\theta$. Thus the total rotation is proportional to $\cos\theta$. The rotation is considered to be a manifestation of photon spin.

- In problem 7, the energy density in the near field of a magnetic moment m was calculated. Show that the energy stored in the field outside a sphere of radius r_0 is given by $U = m^2 \mu_0/(12\pi r_0^3)$. (Hint: let m be in the z direction.)
- The total relativistic energy U of a particle is given by the expression $U^2 = |\mathbf{p}|^2 c^2 + M^2 c^4$, where \mathbf{p} is the particle's momentum, M is its rest mass, and c is the speed of light. The particle is struck by a photon of momentum \mathbf{p}_1 and energy $U_1 = |\mathbf{p}_1|c$. Show that an assumption of *permanent* photon absorption by the particle is incompatible with simultaneous conservation of energy and momentum. The absorption can only be for a short time.

B.2. Answer to Problem 5

5. The electric and magnetic fields are manifestations of the same vector potential $[\mathbf{A}]$ and are related by Eq. [4]. Thus the two calculations are simply two methods of obtaining the same result and the two voltages should not be added.

REFERENCES

- Hoult DI. 1989. The magnetic resonance myth of radio waves. *Concepts Magn Reson* 1:1–5.
- Hoult DI, Bhakar B. 1996. NMR signal reception: virtual photons and coherent spontaneous emission. *Concepts Magn Reson* 9:277–297.
- Purcell EM. 1948. Nuclear magnetism in relation to problems of the liquid and solid states. *Science* 107:433–440.
- Dicke RH. 1954. Coherence in spontaneous emission processes. *Phys Rev* 93:99–110.
- Bloembergen N, Pound RV. 1954. Radiation damping in magnetic resonance experiments. *Phys Rev* 95:8–12.
- Hoult DI, Ginsberg NS. 2001. The quantum origins of the free induction decay signal and spin noise. *J Magn Reson* 148:182–199.
- Srivastava Y, Widom A. 1987. Quantum electrodynamic processes in electrical engineering circuits. *Phys Rep* 148:1–65.
- Born M. 1962. *Atomic Physics*, 7th edn. London: Blackie.

9. Feynman RP, Leighton RB, Sands M. 1964. *The Feynman Lectures in Physics*, Vol. II. Reading: Addison-Wesley.
10. Jackson JD. 1975. *Classical Electrodynamics*, 2nd edn. New York: Wiley.
11. Ohanian HC. 1988. *Classical Electrodynamics*. Boston: Allyn and Bacon.
12. Purcell EM. 1985. *Electricity and Magnetism*, 2nd edn. New York: McGraw-Hill.
13. Taylor EF, Wheeler JA. 1966. *Spacetime Physics*. San Francisco: W. H. Freeman.
14. Hanson LG. 2008. Is quantum mechanics necessary for understanding magnetic resonance? *Concepts Magn Reson A* 32:329–340.
15. Landau LD, Lifshitz EM. 1960. *Electrodynamics of Continuous Media*. Oxford: Pergamon Press.
16. Hoult DI, Richards RE. 1976. The signal-to-noise ratio of the nuclear magnetic resonance experiment. *J Magn Reson* 24:71–85.
17. Insko EK, Elliott MA, Schotland JC, Leigh JS. 1998. Generalized reciprocity. *J Magn Reson* 131:111–117.
18. Gough W. 1986. The angular momentum of radiation. *Eur J Phys* 7:81–87.
19. Landsman NP. 2006. Between classical and quantum. In: Earman J, Butterfield J, eds. *Philosophy of Physics*. Amsterdam: North-Holland.
20. Macomber JD. 1968. How does a crossed-coil NMR spectrometer work? *Spectrosc Lett* 1:131–137.
21. Abragam A. 1961. *The Principles of Nuclear Magnetism*. Oxford: Clarendon Press.
22. Bloch F. 1946. Nuclear induction. *Phys Rev* 70:460–474.
23. Pound RV, Purcell EM. 1946. Measurement of magnetic resonance absorption by nuclear moments in a solid. *Phys Rev* 69:681.
24. Hahn EL. 1950. Nuclear induction due to free Larmor precession. *Phys Rev* 77:297–298.
25. Tavis M, Cummings FW. 1968. Exact solution for an N-molecule-radiation-field Hamiltonian. *Phys Rev* 170:379–384.
26. Rosenthal J. 1968. Comments on “How does a crossed-coil NMR spectrometer work?” *Spectrosc Lett* 1:255–257.
27. Macomber JD. 1968. Reply to “Comments on ‘How does a crossed-coil NMR spectrometer work?’” *Spectrosc Lett* 1:265–270.
28. Dicke RH. 1968. Discussion on “How does a crossed-coil NMR spectrometer work?” *Spectrosc Lett* 1:415–419.
29. Stevens KWH. 1961. The Hamiltonian formalism of damping in a tuned circuit. *Proc Phys Soc* 77:515–525, and references therein.
30. Feynman RP. 1949. Space-time approach to quantum electrodynamics. *Phys Rev* 76:769–789.
31. Bleaney BI, Bleaney B. 1965. *Electricity and Magnetism*, 2nd edn. Oxford: Clarendon Press. pp 263–267.
32. Hoult DI. 1979. Fast recovery, high sensitivity NMR probe and preamplifier for low frequencies. *Rev Sci Instrum* 50:193–200.
33. Hoult DI. 1984. Fast recovery with a conventional probe. *J Magn Reson* 57:394–403.
34. Roemer PB, Edelstein WA, Hayes CE, Souza SP, Mueller OM. 1990. The NMR phase array. *Magn Reson Med* 16:192–225.
35. Faye J. 2008. Copenhagen Interpretation of Quantum Mechanics. In: Zalta EN ed. *The Stanford Encyclopedia of Philosophy* (Fall 2008 Edition). Stanford University. Available at: <http://plato.stanford.edu/archives/fall2008/entries/qm-copenhagen>. Accessed: 2009.
36. Cramer JG. 1986. The transactional interpretation of quantum mechanics. *Rev Mod Phys* 58:647–688.
37. Leach J, Padgett MJ, Barnett SM, Franke-Arnold S, Courtial J. 2002. Measuring the orbital angular momentum of a single photon. *Phys Rev Lett* 88:257901.
38. Fermi E. 1922. Über einen Widerspruch zwischen der elektrodynamischen und der relativistischen Theorie der elektromagnetischen Masse. *Z Physik* 24:340–346.
39. Moylan P. An elementary account of the factor of 4/3 in electromagnetic mass. *Am J Phys* 63:818–820.
40. Goldstein H. 1980. *Classical Mechanics*, 2nd edn. Reading: Addison-Wesley. pp 232–235.
41. Cohen-Tannoudji C, Dupont-Roc J, Grynberg G. 1989. *Photons and Atoms: Introduction to Quantum Electrodynamics*. New York: Wiley.
42. Feynman RP. 1985. *QED: The Strange Theory of Light and Matter*. Princeton: Princeton UP.
43. Powell JL, Crasemann B. 1961. *Quantum Mechanics*. Reading: Addison-Wesley.
44. Davis P. 1989. *The New Physics*. Cambridge: Cambridge UP.
45. Virtual Particle. Available at: http://en.wikipedia.org/wiki/Virtual_particle. Accessed: 2009.
46. Chabanov AA, Genack AZ. 2001. Photon localization in resonant media. *Phys Rev Lett* 87:153901.
47. Motchenbacher CD, Connelly JA. 1993. *Low Noise Electronic System Design*. New York: Wiley.

BIOGRAPHY



David Hoult, a member of the Journal's editorial board, is an alumnus of the University of Oxford and a Principal Research Officer with the National Research Council of Canada. His research interests cover all aspects of the engineering physics of magnetic resonance (MR). He has published nearly 70 papers, is coauthor of a book on magnetic resonance technology and has delivered more than 100 lectures in many countries. He is the recipient of numerous awards, including the Gold Medal of the International Society of Magnetic Resonance in Medicine, of which he is a charter member. He is an Associate Editor of *Magnetic Resonance in Medicine* and is, or has been, on the editorial boards of several other journals. His recent research interests are the quantum origins of the MR signal and spin noise, detection of ferromagnetic objects for MRI safety, and the design of MR instrumentation that uses Cartesian feedback to enable instrument calibration in both single- and multi-coil transmission and reception.